



## PTSS215 ACCESSORY MOUNTING INSTRUCTIONS

*Use these instructions in conjunction with your main manual to properly assemble your gas grill. Refer to the main manual for safety, operating, cleaning and maintenance instructions.*



**WARNING!** Clearance to combustibles as outlined in your main manual and specified on your grill's rating plate must be maintained.



**WARNING!**

- This grill is not to be used while the vessel is in motion.
- When operating the grill on a vessel, only 8 oz. cylinders that are DOT approved (2P2Q) can be used in the United States. In Canada a 16 oz. cylinder may be used. These cylinders are available at your local marina or hardware store.
- This grill is not to be mounted on a railing while the boat is in motion. It is highly recommended that the grill head is removed and stored away before casting off.

Propane and butane can be more dangerous than gasoline. These gases are heavier than air. If they escape, they collect in the lower parts of the vessel and are very difficult to remove. Make sure all propane appliances and cylinders are properly secured, protected and ventilated, so that escaping gas can not reach bilges or other enclosed spaces. The equipment installation should meet Federal Government standards.



**WARNING!**

- Make sure that all valves are working properly, and that all connections are tight.
- When used on a small vessel, this unit must be installed according to the manufacture's instructions.
- This appliance is not to be installed on any small commercial vessel that is carrying passengers.
- Do not install or store this appliance in a manner that permits or is likely to permit ingress or trapping of the gas below deck.
- This grill is not to be operated within a cabin or any other enclosed area. This grill is to be used outdoors only.

## Rail Mount Instructions

- Place mount "A" on the outside of the railing, with the mounting platform facing up.
- Attach mount "B" to mount "A" using the four 1/4-20 x 1" bolts.
- Level the platform and tighten the top two bolts first. Be sure the platform is pinched tight before tightening the bottom two bolts.
- The platform can also be adjusted left to right by loosening the top two bolts and centre pivot screw. Once the platform is adjusted, tighten all three fasteners.
- Once the platform is level in both directions, the grill can be mounted:
  - Lock the lid of the grill closed with the latch.
  - Hold the grill by the handle with one hand, place the other hand under the grill in the centre of the front tapered surface.
  - Place the grill bottom on the platform and slide it forward to engage the tab protruding from the bottom of the grill. Ensure that the tab is properly engaged.
  - When the dimples on the bottom of the unit line up with the holes on the platform, the latch is ready to be fastened.
- Under extreme conditions, the bracket may pivot around the railing. A centre hole has been provided to allow a bolt to be fastened through the rail to prevent the grill from pivoting on the rail.
- Once the grill has been attached, thread the regulator (clockwise) into the regulator mount. On tube burner version, lift the burner slightly to align it with the orifice. Tighten by hand.
- To fasten the regulator locking bracket, locate it at the bottom back corner of the regular mount and turn the regulator until the gas inlet is aligned with the hole in the regulator locking bracket. Slide the locking bracket forward until the two tabs engage into the slots on the regulator mount. Tap in firmly.
- Attach the cylinder to the regulator by turning clockwise. (Be sure not to cross thread the cylinder).

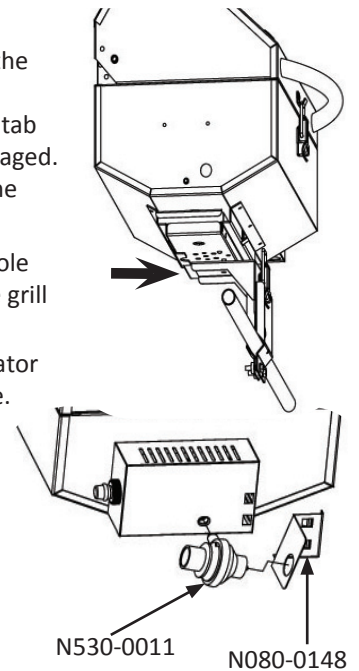
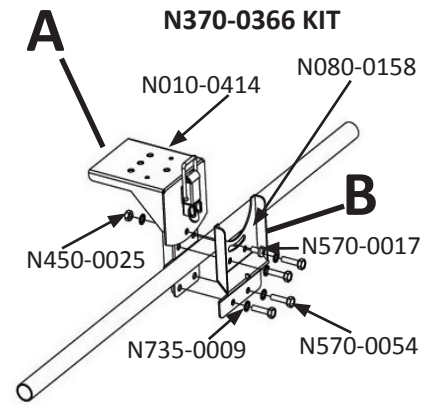

## Wall Mount Instructions

- Using the two holes provided in the vertical tube, mount the bracket to the wall.
- Ensure minimum clearance to combustibles are maintained, 4" (100mm) to sides, and 6" (150mm) from rear.
- Do not locate the grill under unprotected combustible construction.
- The platform may be swivelled by removing the two #8 x 3/8" flathead phillips screws and turning the platform to the desired angle. Replace the two screws and tighten.
- Once the platform is located in the desired position, the grill can be mounted:
  - Lock the lid of the grill closed with the latch.
  - Hold the grill by the handle with one hand, place the other hand under the grill in the centre of the front tapered surface.
  - Place the grill bottom on the platform and slide it forward to engage the tab protruding from the bottom of the grill. Ensure that the tab is properly engaged.
  - When the dimples on the bottom of the unit line up with the holes on the platform, the latch is ready to be fastened.
- Once the grill has been attached, thread the regulator (clockwise) into the regulator mount. On tube burner version, lift the burner slightly to align it with the orifice. Tighten by hand.
- To fasten the regulator locking bracket, locate it at the bottom back corner of the regulator mount and turn the regulator until the gas inlet is aligned with the hole in the regulator locking bracket. Slide the locking bracket forward until the two tabs engage into the slots on the regulator mount. Tap in firmly.
- Attach the cylinder to the regulator by turning clockwise. (Be sure not to cross thread the cylinder).

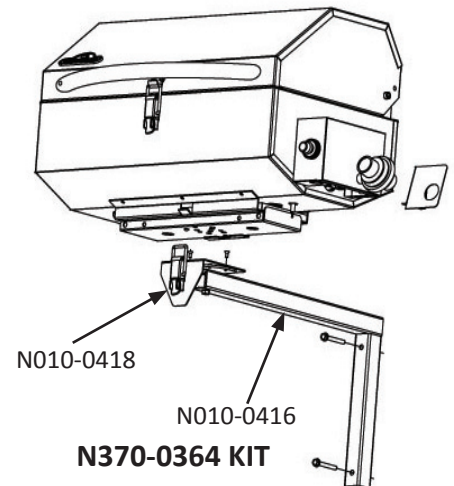

## Trailer Ball Mounting Instructions

1. Place the ball mount over the ball on your drawbar or bumper.
2. Tighten the two wing screws until the mount is firmly held in place.
3. Once the mounting arm is tight, the grill can be mounted:
  - a. Lock the lid of the grill closed with the latch.
  - b. Hold the grill by the handle with one hand, place the other hand under the grill in the centre of the front tapered surface.
  - c. Place the grill bottom on the platform and slide it forward to engage the tab protruding from the bottom of the grill. Ensure that the tab is properly engaged.
  - d. When the dimples on the bottom of the unit line up with the holes on the platform, the latch is ready to be fastened.
4. Once the grill has been attached, thread the regulator (clockwise) into the regulator mount. On tube burner version, lift the burner slightly to align it with the orifice. Tighten by hand.
5. To fasten the regulator locking bracket, located it at the bottom back corner of the regulator mount and turn the regulator locking bracket. Slide the locking bracket forward until the two tabs engage into the slots on the regulator mount. Tap in firmly.
6. Attach the cylinder to the regulator by turning clockwise. (Be sure not to cross thread the cylinder).

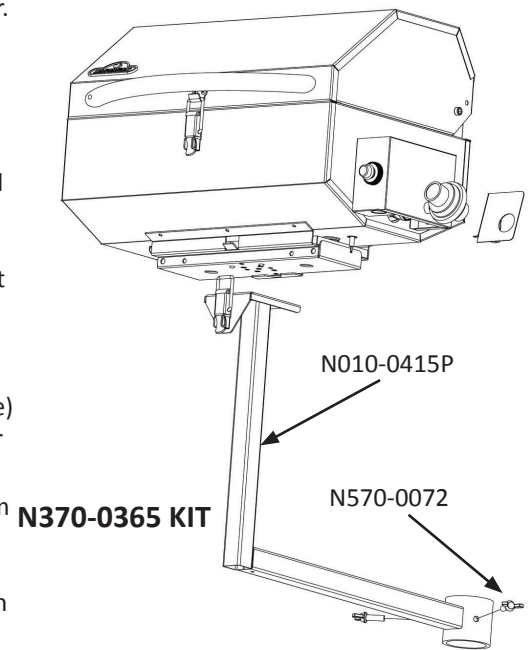

## Post Mounting Instructions

1. Remove all the parts from the packaging.
2. Attach the post to the casting using four 1/4-20 x 1" hex head bolts. Ensure that the holes on the back side of the post face the same direction as the groove on the bottom back of the foot casting.
3. Place the spacers provided on the three nutserts that are closest to the front of the post.
4. Place the platform with the latch to the front onto the three spacers. Attach with the three 1/4-20 x 1 3/4" flat head bolts. Tighten firmly in place.
5. Attach the back post cover with the two #8 screws provided.
6. Once the post is completely assembled, the grill can be mounted:
  - a. Lock the lid of the grill closed with the latch.
  - b. Hold the grill by the handle with one hand, place the other hand under the grill in the centre of the front tapered surface.
  - c. Place the grill bottom on the platform and slide it forward to engage the tab protruding from the bottom of the grill. Ensure that the tab is properly engaged.
  - d. When the dimples on the bottom of the unit line up with the holes on the platform, the latch is ready to be fastened.
7. Once the grill has been attached, thread the regulator (clockwise) into the regulator mount. On tube burner version, lift the burner slightly to align it with the orifice. Tighten by hand.
8. To fasten the regulator locking bracket, located it at the bottom back corner of the regulator mount and turn the regulator until the gas inlet is aligned with the hole in the regulator locking bracket. Slide the locking bracket forward until the two tabs engage into the slots on the regulator mount. Tap in firmly.
9. Attach the cylinder to the regulator by turning clockwise. (Be sure not to cross thread cylinder).

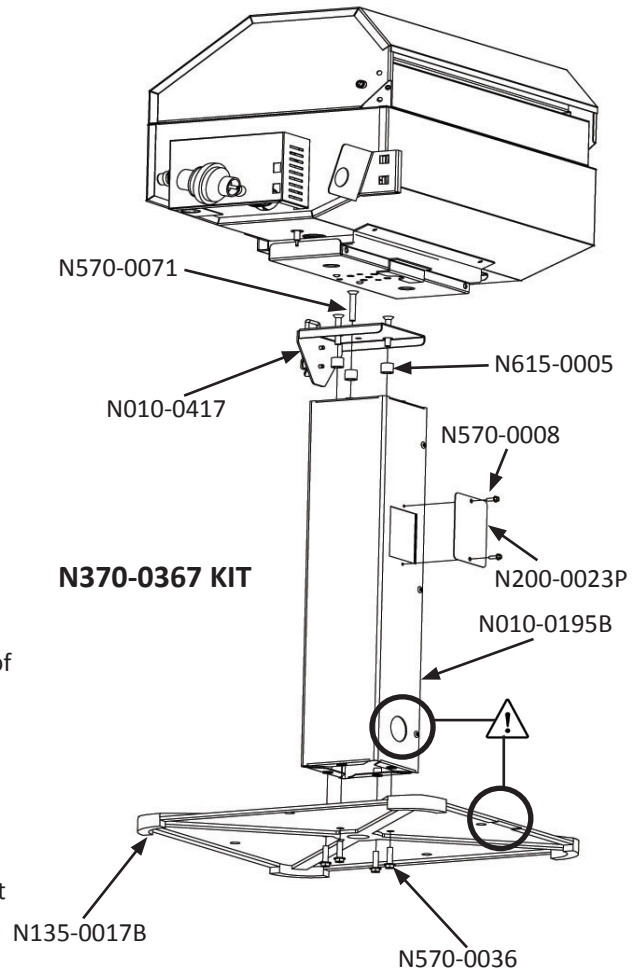

**NOTES**