

This gas grill must be used only outdoors in a well-ventilated space and must not be used inside a building, garage, screened-in porch, gazebo or any other enclosed area.

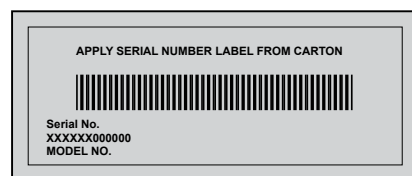

PRESTIGE II 600



DANGER

IF YOU SMELL GAS:

- Shut off gas to the appliance.
- Extinguish any open flame.
- Open lid.
- If odor continues, keep away from the appliance and immediately call your gas supplier or fire department.



WARNING

Do not try to light this appliance without reading the "LIGHTING" instructions section of this manual.

Do not store or use gasoline or other flammable liquids or vapors in the vicinity of this or any other appliance. An L.P. cylinder not connected for use must not be stored in the vicinity of this or any other appliance. If the information in these instructions is not followed exactly, a fire or explosion may result, causing property damage, personal injury or death.

Notice to Installer: Leave these instructions with the grill owner for future reference.



Manufactured by: Napoleon Appliance Corp.,
214 Bayview Dr., Barrie, Ontario, Canada L4N 4Y8 Phone: (705)726-4278
Fax: (705)725-2564 email: wecare@napoleonproducts.com web site: www.napoleongrills.com





All NAPOLEON gas grills are manufactured under the strict Standard of the world recognized ISO 9001-2008 Quality Assurance Certificate.

NAPOLEON products are designed with superior components and materials, and are assembled by trained craftsmen who take great pride in their work. The burner and valve assembly are leak tested and test-fired at a quality test station. This grill has been thoroughly inspected by a qualified technician before packaging and shipping to ensure that you, the customer, receive the quality product you expect from NAPOLEON.



Napoleon Gas Grill President's Limited Lifetime Warranty

NAPOLEON warrants the following materials and workmanship in your new NAPOLEON gas grill against defects for as long as you own the gas grill. This covers aluminum castings (excluding paint), stainless steel base, stainless steel control panel (excluding screen printing), stainless steel burners, stainless steel rod cooking grids, stainless steel side shelves, LUXIDIO® side shelf end caps, wheels, knobs, porcelain enameled lids and stainless steel lids, subject to the following conditions: During the first ten years NAPOLEON will provide replacement parts at our option free of charge. From the eleventh year to lifetime, NAPOLEON will provide replacement parts at 50% of the current retail price.

Components such as stainless steel sear plates, ceramic infrared burners (excluding screens), cast iron cooking grids, igniter (excluding batteries), temperature gauge and brass valves are covered and NAPOLEON will provide parts free of charge during the first three years of the limited warranty.

Components such as regulators, casters, stainless steel warming racks, hoses and connectors, fasteners and accessories are covered and NAPOLEON will provide parts free of charge during the first year of the limited warranty.

NAPOLEON shall not be liable for any transportation charges, labor costs or export duties.

Conditions And Limitations

"NAPOLEON warrants its products against manufacturing defects to the original purchaser only, provided that the purchase was made through an authorized NAPOLEON dealer and is subject to the following conditions and limitations:"

This factory warranty is non-transferable and may not be extended what-so-ever by any of our representatives.

The gas grill must be installed by a licensed, authorized service technician or contractor. Installation must be done in accordance with the installation instructions included with the product and all local and national building and fire codes.

This limited warranty does not cover damages caused by misuse, lack of maintenance, grease fires, hostile environments, accident, alterations, abuse or neglect and parts installed from other manufacturers will nullify this warranty.

This limited warranty further does not cover any scratches, dents, painted finishes, corrosion or discoloring by heat, abrasive and chemical cleaners, nor chipping on porcelain enamel parts, nor any components used in the installation of the gas grill.

Should deterioration of parts occur to the degree of non-performance within the duration of the warranted coverage, a replacement part will be provided.

In the first year only, this warranty extends to the replacement of warranted parts, which are defective in material or workmanship provided that the product has been operated in accordance with the operation instructions and under normal conditions.

After the first year, with respect to this President's Limited Lifetime Warranty NAPOLEON may, at its discretion, fully discharge all obligations with respect to this warranty by refunding to the original warranted purchaser the wholesale price of any warranted but defective part(s).

NAPOLEON will not be responsible for the installation, labor or any other costs or expenses related to the re-installation of a warranted part, and such expenses are not covered by this warranty.

Notwithstanding any provision contained in this President's Limited Lifetime Warranty NAPOLEON's responsibility under this warranty is defined as above and it shall not in any event extend to any incidental, consequential, or indirect damages.

This warranty defines the obligation and liability of NAPOLEON with respect to the NAPOLEON gas grill and any other warranties expressed or implied with respect to this product, its components or accessories are excluded.

NAPOLEON neither assumes, nor authorizes any third party to assume, on its behalf, any other liabilities with respect to the sale of this product.

NAPOLEON will not be responsible for: over firing, blow outs caused by environmental conditions such as strong winds, or inadequate ventilation,

Any damages to the gas grill due to weather damage, hail, rough handling, damaging chemicals or cleaners will not be the responsibility of NAPOLEON.

The bill of sale or copy will be required together with a serial number and a model number when making any warranty claims from NAPOLEON.

NAPOLEON reserves the right to have its representative inspect any product or part prior to honoring any warranty claim.

NAPOLEON shall not be liable for any transportation charges, labor costs, or export duties.



WARNING! Failure to follow these instructions could result in property damage, personal injury or death. Read and follow all warnings and instructions in this manual prior to operating grill.

Safe Operating Practices

- This gas grill must be assembled exactly according to the instructions in the manual. If the grill was store assembled, you must review the assembly instructions to confirm correct assembly and perform the required leak tests before operating the grill.
- Read the entire instruction manual before operating the gas grill.
- This gas grill must be used only outdoors in a well-ventilated space and must not be used inside a building, garage, screened-in porch, gazebo or any other enclosed area.
- This gas grill must not be installed in or on recreational vehicles and/or boats.
- Do not locate unit in windy settings. High winds adversely affect the cooking performance of the gas grill.
- Under no circumstances should this gas grill be modified.
- Do not operate unit under overhead combustible construction.
- Maintain proper clearance to combustibles (16" (410mm) to rear of unit, 7" (178mm) to sides). Additional clearance of (24" (610mm) is recommended near vinyl siding or panes of glass.
- Gas must be turned off at the propane cylinder or at the natural gas supply valve when the gas grill is not in use.
- Do not attempt to use a cylinder that is not equipped with a QCC1 type connection.
- When the propane cylinder is connected to the appliance, the gas grill and cylinder must be stored outdoors in a well-ventilated space.
- When the gas grill is to be stored indoors, the connection between the propane cylinder and the gas grill must be disconnected and the cylinder removed and stored outdoors in a well ventilated space out of reach of children. Disconnected cylinders must not be stored in a building, garage or any other enclosed area. Natural gas units must be disconnected from the supply when being stored indoors.
- Inspect the fuel supply hose before each use. If there is evidence of excessive abrasion or wear or the hose is cut, it must be replaced prior to using the gas grill with a replacement hose assembly specified by the grill manufacturer.
- Do not route hose underneath drip pan - proper hose clearance to bottom of unit must be maintained.
- Hose must not run behind the front leg. It must run around the front side of leg (if applicable).
- Leak test the unit before initial use, annually, and whenever any gas components are replaced.
- Follow lighting instructions carefully when operating grill.
- Burner controls must be off when turning supply cylinder valve on.
- The lid is to be closed during the gas grill preheating period on all models except the BISZ300NFT/PFT and the built-in side burner BISB245.
- The BISZ300NFT/PFT and the built-in side burner BISB245 are supplied with a flat cover for storage and protection from the elements. Never place this cover on the grill while hot or operating. Allow grill to cool completely before covering.
- Adults and especially children should be alerted to the hazards of high surface temperatures. Young children should be supervised near the gas grill.
- Do not leave grill unattended when operating.
- Do not light burners with lid closed.
- Do not operate rear burner with main burners operating.
- Do not move grill when hot or operating.
- Do not use condiment tray to store lighters, matches or any other combustibles.
- Keep any electrical supply cord and fuel supply hose away from any heated surfaces.
- Ensure sear plates are positioned properly according to sear plate installation instructions. The holes must be towards the front of the gas grill (if applicable).
- Clean grease tray and sear plates regularly to avoid build-up, which could lead to grease fires.
- Remove warming rack before lighting rear burner. The extreme heat will damage the warming rack.
- Inspect infrared burner venturi tube for spider webs and other obstructions periodically. Clean the tubes completely if you find any such obstructions.
- Do not allow cold water (rain, sprinkler, hose, etc.) to come in contact with heated unit. A large temperature differential can cause chipping in the porcelain.
- Do not allow cold water (rain, sprinkler, hose, etc.) to come in contact with ceramic burners. A large temperature differential can cause cracking in the ceramic tile.
- Do not use a pressure washer to clean any part of the unit.

General Information

This Gas Barbecue Is Certified Under Canadian And American National Standards, CAN/CGA-1.6-M95 and ANSI Z21.58 -1995 respectively for Outdoor Gas Grills and should be installed to conform with local codes. In absence of local codes, install to the current CAN1-B149.2 Propane Installation Code in Canada or to the National Fuel Gas Code, ANSI Z223.1 in the United States.

If a rotisserie motor is used, it must be electrically grounded in accordance with local codes or, in absence of local codes, with the current CSA C22.1 Canadian Electrical Code in Canada or the National Electrical Code, ANSI/NFPA 70 in the United States.

California proposition 65: The burning of gas fuel creates by-products, some of which are on the list as substances known by the State of California to cause cancer or reproductive harm. When cooking with gas, always ensure adequate ventilation to the unit, to minimize exposure to such substances.

Propane Cylinder Specifications



WARNING! If these instructions are not followed exactly, a fire causing death or serious injury may occur.

A dented or rusty cylinder may be hazardous and should be checked by your propane supplier. Never use a cylinder with a damaged valve. Use only a propane supply cylinder constructed and marked in accordance with the specifications for LP-gas cylinders of the National Standard of Canada, CAN/CSA-b339, Cylinders, Spheres and Tubes for Transportation of Dangerous Goods; and Commission, as applicable or the Specifications for LP-Gas Cylinders of the U.S. Department of Transportation (D.O.T.). This appliance has been designed for use with a 20 lb. (9.1 kg) size propane cylinder only (not supplied).

The propane cylinder must be provided with a cylinder connection device compatible with the connection for outdoor cooking appliances. The propane cylinder must be provided with a shut-off valve terminating in a propane cylinder valve type QCC1, and a safety relief device having direct communication with the vapor space of the cylinder. The cylinder supply system must be arranged for vapor withdrawal and the cylinder shall include a collar to protect the cylinder valve. The cylinder shall incorporate a listed OPD (overfill protection device). Do not store a spare LP-gas cylinder under or near this appliance. Never fill the cylinder beyond 80 percent full.

Use only the pressure regulator and hose assembly provided with this barbecue. Replacement pressure regulators and hose assemblies must be specified by the manufacturer. Do not store a spare propane cylinder on the shelf beneath the barbecue.

The regulator supplies a pressure of 11 inches. water column to the gas grill and has a QCC1 type fitting. Cylinders to be used with this unit must be supplied with a QCC1 cylinder valve. A QCC1 cylinder has a positive seating connection, which will not allow gas flow until a positive seal has been achieved. It is also equipped with an excess flow device. In order to attain full flow to the grill, the valves must be in the off position when the cylinder valve is turned on.

Gas Hook-Up Instructions



WARNING! A fire will result if the gas supply hose makes contact with the underside of the grill or drip pan.

Propane Cylinder Installation: Set cylinder into hole in bottom shelf.

Cylinder Connection: Ensure the gas regulator hose is kink free. Remove the cap or plug from the cylinder fuel valve. Insert the black QCC1 regulator nipple onto the QCC1 fuel valve. Hand tighten clockwise. Do not use tools. Leak test all joints prior to using the grill. A leak test must be performed annually and each time a cylinder is hooked up or if a part of the gas system is replaced.

If this grill is to be connected directly to a house propane gas supply line, follow the instructions for the natural gas hook-up. Optional side burners must also follow the natural gas hook-up instructions. Note: The propane tank heat shield is not required when the grill is connected to a fixed fuel supply, as its sole function is to shield the propane tank normally used with the grill. Ensure that the supply pressure is 11 inches water column.

Natural Gas Hook-Up: These connections must be made by a licensed gas fitter. This natural gas grill is supplied with a gas supply hose (complete with a quick disconnect) designed for natural gas and certified for outdoor use. The gas grill is designed to operate at an inlet pressure of 7 inches water column. Piping and valves upstream of the quick disconnect are not supplied. The installation must comply with CAN B149.1 Natural Gas and Propane installation code in Canada, or to the National Fuel Gas Code, ANSI Z223.1 in the United States. The gas supply pipe must be sufficiently sized to supply the BTU/h specified on the rating plate, based on the length of the piping run.

The quick disconnect must not be installed in an upward direction and a readily accessible manual shut-off valve must be installed upstream of, and as close to, the quick disconnect as is feasible. The flared end of the hose must be connected to the fitting on the end of the manifold tube or flex tube (if applicable) as illustrated in the Natural Gas Hose Attachment diagram. Tighten using two wrenches. (Do not use thread sealer/pipe dope.) Leak test all joints prior to using the gas grill.



WARNING!

- The installation must be performed by a licensed gas fitter, and all connections must be leak tested before operating the grill.
- Do not route hose underneath the drip pan.
- Do not route hose between bottom shelf space and back panel.
- Do not route hose over top of rear panel.
- Ensure all hose connections are tightened using two wrenches. Do not use Teflon tape or pipe dope on any hose connection.
- Ensure the hose does not contact any high temperature surfaces or it may melt and leak causing a fire.
- Leak test all the connections using a soap and water solution as per the leak testing instructions found in the manual.
- The outdoor cooking gas appliance and its individual shutoff valve must be disconnected from the gas supply piping system during any pressure testing of that system at test pressures in excess of 0.5 psi (3.5 kPa).
- The outdoor cooking gas appliance must be isolated from the gas supply piping system by closing its individual manual shutoff valve during any pressure testing of the gas supply piping system at test pressures equal to or less than 1/2 psi (3.5 kPa).

Leak Testing Instructions



WARNING! A leak test must be performed annually and each time a cylinder is hooked up or if a part of the gas system is replaced.



WARNING! Never use an open flame to check for gas leaks. Be certain no sparks or open flames are in the area while you check for leaks. Sparks or open flames will result in a fire or explosion, damage to property, serious bodily injury, or death.



Leak testing: This must be done before initial use, annually, and whenever any gas components are replaced or serviced. Do not smoke while performing this test, and remove all sources of ignition. See Leak Testing Diagram for areas to check. Turn all burner controls to the off position. Turn gas supply valve on.



Brush a half-and-half solution of liquid soap and water onto all joints and connections of the regulator, hose, manifolds and valves.



Bubbles will indicate a gas leak. Either tighten the loose joint or have the part replaced with one recommended by the Napoleon Customer Care department and have the grill inspected by a certified gas installer.

If the leak cannot be stopped, immediately shut off the gas supply, disconnect it, and have the grill inspected by a certified gas installer or dealer. Do not use the grill until the leak has been corrected.

Lighting Instructions

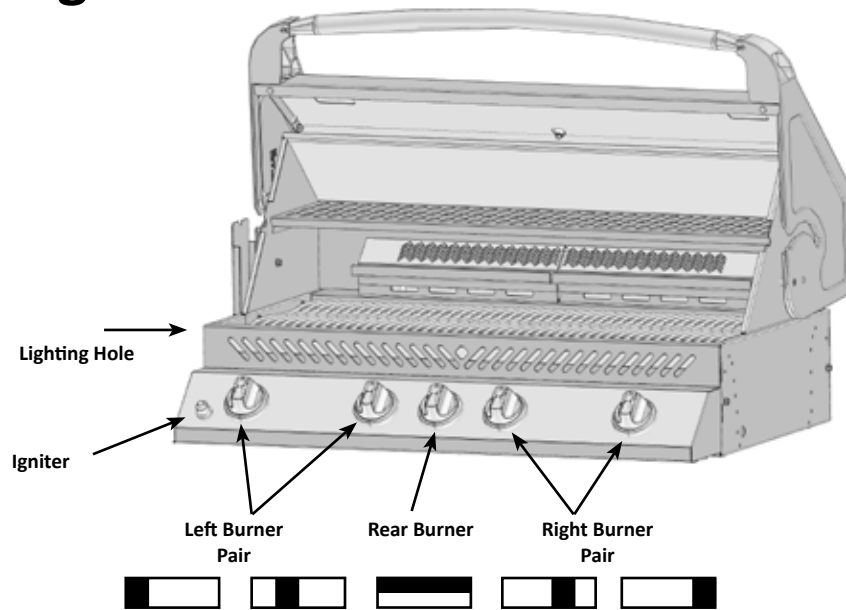

WARNING! Open lid.

Off Position



WARNING! Ensure all burner controls are in the off position. Slowly turn on the gas supply valve.

Main Tube Burner Lighting	Rear Burner Lighting (if equipped)	Side Burner Lighting (optional)
1. Open grill lid	1. Open grill lid	1. Open burner cover.
2. Turn left burner control of either pair to high position.	2. Remove warming rack.	2. Turn side burner control to high position.
3. Press and hold igniter button until burner lights, or light by match.	3. Turn rear burner control to high position.	3. Press and hold igniter button until burner lights, or light by match.
4. If ignition is not immediate, turn burner control off. Wait 5 minutes. Repeat.	4. Press and hold igniter button until burner lights, or light by match.	4. If ignition is not immediate, turn burner control off. Wait 5 minutes. Repeat.
5. With the left burner operating on high, turn the right burner of the same pair to high.	5. If ignition is not immediate, turn burner control off. Wait 5 minutes. Repeat.	
6. To light the other burner pair, repeat the procedure.		



WARNING! The propane cylinder is equipped with an excess flow device. Unless all burners are turned off prior to turning the cylinder on, only small flames and low heat will be achievable.



WARNING! Do not use rear burner while operating main burner.

Cooking Instructions

Initial Lighting: When lit for the first time, the gas grill emits a slight odor. This is a normal temporary condition caused by the “burn-in” of internal paints and lubricants used in the manufacturing process and does not occur again. Simply run the main burners on high for approximately one-half hour.

Main Burner Use: When searing foods, we recommend preheating the grill by operating all main burners in the high position with the lid closed for approximately 10 minutes. Food cooked for short periods of time (fish, vegetables) can be grilled with the lid open. Cooking with the lid closed will ensure higher, more even temperatures that can reduce cooking time and cook meat more evenly. Food that has a cooking time longer than 30 minutes, such as roasts, can be cooked indirectly (with the burner lit opposite to the food placement). When cooking very lean meats, such as chicken breasts or lean pork, the grids can be oiled before pre-heating to reduce sticking. Cooking meat with a high degree of fat content can create flare-ups. Either trim the fat or reduce temperatures to inhibit this. Should a flare-up occur, move food away from the flames and reduce the heat. Leave the lid open. See *Your All Season Grill* cookbook by Napoleon for more detailed instructions.

Direct Cooking: Place food to be cooked on the grill directly over the heat. This method is generally used for searing or for foods that do not require prolonged cooking times such as hamburgers, steaks, chicken pieces, or vegetables. The food is first seared to trap-in the juices and flavor, and then the temperature is lowered to finish cooking the food to your preference.

Indirect Cooking: With one or more burners operating, place food to be cooked on the grill over a burner that is not operating. The heat circulates around the food, cooking slowly and evenly. Cooking with this method is much the same as cooking in your oven and is generally used for larger cuts of meats such as roasts, chickens or turkeys, but can also be used for cooking foods that are prone to flare-ups or for smoking foods. Lower temperatures and slower cooking times result in tender foods.

Rear Burner Use (If Equipped): Remove the warming rack prior to use. Cooking grids should also be removed if they interfere with the rotisserie. The rear burner is designed to be used in conjunction with the rotisserie kit (included with most rear burner units) available from your dealer. See the rotisserie kit assembly instructions.

To use the counterbalance - remove the rotisserie motor from the gas grill. Place the spit with meat being cooked across the hangers inside the grill. The meat will naturally hang with the heavy side down. Tighten the counterbalance arm and weight so the arm is facing up. Slide the counterweight in or out to balance the load and tighten in place. Re-install the motor and begin cooking. Place a metal dish underneath the meat to collect drippings for basting and naturally delicious gravy. Basting liquid may be added as required. To seal in juices, first operate rear burner on high until brown, then reduce the heat to thoroughly cook foods. Keep the lid closed for best results. Your roasts and fowl will brown perfectly on the outside and stay moist and tender on the inside. For example, a 3 pound chicken on the rotisserie will be done in approximately 1½ hours on medium to high. See ‘Your all Season Grill’ cookbook by Napoleon for more detailed instructions.



WARNING! Barbecue sauce and salt can be corrosive and will cause rapid deterioration of the gas grill components unless cleaned regularly. When finished cooking disassemble rotisserie components, wash thoroughly with warm soapy water and store indoors.

Side Burner Use (if equipped): The side burner can be used like any stove top burner, for gravies, soups etc. For best performance, the gas grill should be located with the side burner protected from the wind.



WARNING! Never grill food directly on the side burner grate. It is designed for use with pots and pans only.

Cleaning Instructions



WARNING! Always wear protective gloves and safety glasses when cleaning your grill.

WARNING! To avoid the possibility of burns, maintenance should be done only when the grill is cool. Avoid unprotected contact with hot surfaces. Ensure all burners are turned off. Clean grill in an area where cleaning solutions will not harm decks, lawns, or patios. Do not use oven cleaner to clean any part of this gas grill. Do not use a self-cleaning oven to clean cooking grids or any other parts of the gas grill. Barbecue sauce and salt can be corrosive and will cause rapid deterioration of the gas grill components unless cleaned regularly.

Note: Stainless steel tends to oxidize or stain in the presence of chlorides and sulfides, particularly in coastal areas and other harsh environments, such as the warm, highly humid atmosphere around pools and hot tubs. These stains could be perceived as rust, but can be easily removed or prevented. To provide stain prevention and removal, wash all stainless steel surfaces every 3-4 weeks or as often as required with fresh water and/or stainless steel cleaner.

Grids And Warming Rack: The grids and warming rack are best cleaned with a brass wire brush during the pre-heating period. Steel wool can be used for stubborn stains. It is normal that stainless grids (if equipped) will discolor permanently from regular usage due to the high temperature of the cooking surface.

Control Panel: The control panel text is printed directly on the stainless steel and with proper maintenance will remain dark and legible. To clean the panel, use only warm soapy water or Continental brand stainless steel cleaner available from your Napoleon dealer. Never apply abrasive cleaners on any stainless surfaces, especially the printed portion of the control panel or the printing will gradually rub off.

Cleaning Inside The Gas Grill: Remove the cooking grids. Use a brass wire brush to clean loose debris from the casting sides and underneath the lid. Scrape the sear plates with a putty knife or scraper, and use a wire brush to remove the ash. Remove the sear plates and brush debris from the burners with the brass wire brush. Sweep all debris from inside the gas grill into the drip pan.

Drip Pan: Accumulated grease is a fire hazard. Clean the drip pan frequently (every 4 – 5 uses or as often as required) to avoid grease buildup. Grease and excess drippings pass through to the drip pan, located beneath the gas grill and accumulate in the disposable grease tray below the drip pan. To access the disposable grease tray or to clean the drip pan, slide the drip pan free of the grill. Never line the drip pan with aluminum foil, sand or any other material as this could prevent the grease from flowing properly. The pan should be scraped out with a putty knife or scraper. Replace the disposable grease tray every 2 – 4 weeks, depending on gas grill usage. For supplies, see your Napoleon Gas Grill dealer.

Cleaning The Outer Grill Surface: Do not use abrasive cleaners or steel wool on any painted, porcelain or stainless steel parts of your Napoleon Grill. Doing so will scratch the finish. Exterior grill surfaces should be cleaned with warm soapy water while the metal is still warm to the touch. To clean stainless surfaces, use a stainless steel or a non-abrasive cleaner. Always wipe in the direction of the grain. Over time, stainless steel parts discolor when heated, usually to a golden or brown hue. This discoloration is normal and does not affect the performance of the grill. Porcelain enamel components must be handled with additional care. The baked-on enamel finish is glass-like, and will chip if struck. Touch-up enamel is available from your Napoleon Grill dealer.

Maintenance Instructions

We recommend this gas grill be thoroughly inspected and serviced annually by a qualified service person.



WARNING! Always wear protective gloves and safety glasses when cleaning your grill.

WARNING! Turn off the gas at the source and disconnect the unit before servicing. To avoid the possibility of burns, maintenance should be done only when the grill is cool. A leak test must be performed annually and whenever any component of the gas train is replaced or gas smell is present.

Combustion Air Adjustment: (This must be done by a qualified gas installer.) The air shutter is factory set and should not need adjusting under normal conditions. Under extreme field conditions, adjustments might be required. When the air shutter is adjusted correctly the flames will be dark blue, tipped with light blue and occasionally yellow.

- With too little air flow to the burner, the flames are lazy yellow and can produce soot.
- With too much air flow, the flames lift erratically and can cause difficulties when lighting.

Adjusting the air shutter:

1. Remove cooking grids and sear plates and leave lid open. You may have to open the door or remove the top drawer (if equipped) to access the air-shutter screw located at the mouth of the burner. The back cover must be removed for rear tube burner air shutter adjustment.

2. Loosen air-shutter lock screw and open or close air shutter as required. The normal opening settings are:

Main Tube Burner	Propane 1/4" (6mm)	Rear Tube Burner	Propane Full Open
	Natural 1/8" (3mm)		Natural 3/8" (10mm)

*Infra-Red burners have no air adjustment.

3. Light the burners and set to high. Visually inspect burner flames. When the shutters are set correctly, turn burners off, tighten locking screws, and replace removed parts. Ensure that the insect screens are installed.

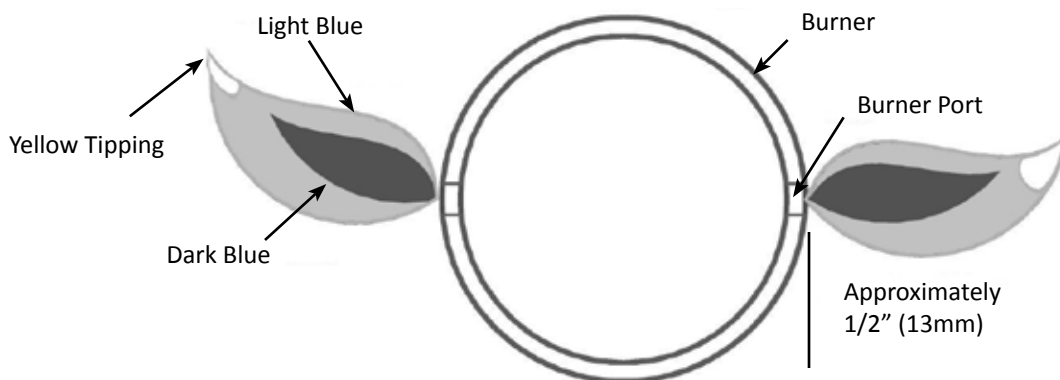

Burner: The burner is made from heavy wall 304 stainless steel, but extreme heat and a corrosive environment can cause surface corrosion to occur. This can be removed with a brass wire brush.

CAUTION! Beware of Spiders.

Spiders and insects are attracted to the smell of propane and natural gas. The burner is equipped with an insect screen on the air shutter, which reduces the likelihood of insects building nests inside the burner but does not entirely eliminate the problem. A nest or web can cause the burner to burn with a soft yellow or orange flame or cause a fire (flashback) at the air shutter underneath the control panel. To clean the inside of the burner, it must be removed from the gas grill: Remove the screw (s) that attaches the burner to the back wall. Slide the burner back and up wards to remove. Cleaning: Use a flexible venturi tube brush to clean the inside of the burner. Shake any loose debris from the burner through the gas inlet. Check the burner ports and valve orifices for blockages. Burner ports can close over time due to cooking debris and corrosion, use an opened paperclip or the supplied port maintenance bit to clean them. Drill out blocked ports using this drill bit in a small cordless drill. The ports are easier to clean if the burner is removed from the grill, but it can also be done with the burner installed. Do not flex the drill bit when drilling the ports, as this will cause the drill bit to break. This drill is for burner ports only, not for the brass orifices (jets) which regulate the flow into the burner. Take care not to enlarge the holes. Ensure the insect screen is clean, tight, and free of any lint or other debris.

Reinstallation: Reverse the procedure to reinstall the burner. Check that the valve enters the burner when installing. Replace sear plate mount and tighten screws to complete reinstallation.



WARNING! When reinstalling the burner after cleaning it is very important that the valve/orifice enters the burner tube before lighting your gas grill. If the valve is not inside the burner tube a fire or explosion could occur.

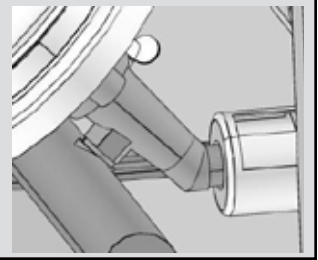

WARNING! Hose: Check for abrasions, melting, cuts, and cracks in the hose. If any of these conditions exist, do not use the gas grill. Have the part replaced by your Napoleon Gas Grill dealer or qualified gas installer.

Aluminum Castings: Clean castings periodically with warm soapy water. Aluminum will not rust, but high temperatures and weathering can cause oxidation to occur on aluminum surfaces. This appears as white spots on the castings. To refinish these areas, clean first and sand lightly with fine sandpaper. Wipe the surface to remove any residue and paint with high temperature barbecue paint. Protect surrounding areas from over-spray. Follow the manufacture's directions for curing.

Troubleshooting

Problem	Possible Causes	Solution
Low heat / Low flame when valve turned to high.	For propane - improper lighting procedure. For natural gas - undersized supply line. For both gases - improper preheating.	Ensure lighting procedure is followed carefully. All gas grill valves must be in the off position when the tank valve is turned on. Turn tank on slowly to allow pressure to equalize. See lighting instructions. Pipe must be sized according to installation code. Preheat grill with both main burners on high for 10 to 15 minutes.
Excessive flare-ups/uneven heat.	Sear plates installed incorrectly. Improper preheating. Excessive grease and ash build on sear plates and in drip pan.	Ensure sear plates are installed with the holes towards the front and the slots on the bottom. See assembly instructions. Preheat grill with both main burners on high for 10 to 15 minutes. Clean sear plates and drip pan regularly. Do not line pan with aluminum foil. Refer to cleaning instructions.
Burners burn with yellow flame, accompanied by the smell of gas.	Possible spider web or other debris, or improper air shutter adjustment.	Thoroughly clean burner by removing. See general maintenance instructions. Open air shutter slightly according to combustion air adjustment instructions. (This must be done by a qualified gas installer.)
Flames lift away from burner, accompanied by the smell of gas, and possibly difficulties in lighting.	Improper air shutter adjustment.	Close air shutter slightly according to combustion air adjustment instructions. (This must be done by a qualified gas installer.)
Burner will not light with the igniter, but will light with a match.	Dead battery / or installed incorrectly. Loose electrode wire or switch terminal wires. Wrong replacement igniter. Improper gap at electrode tip. Lifting flames on burner.	Replace with heavy duty battery. Check that electrode wire is firmly pushed onto the terminal on the back of the igniter. Check that the lead wires from the module to the ignition switch (if equipped) are firmly pushed onto their respective terminals. One spark systems must use a one spark igniter. Ensure that the collector box is tight and the gap between the electrode end and the collector box is between 1/8" - 3/16" (3mm-5mm). The gap can be adjusted by bending the box in or out. Close air shutter slightly - see previous problem.

Problem	Possible Causes	Solution
Humming regulator.	Normal occurrence on hot days.	This is not a defect. It is caused by internal vibrations in the regulator and does not affect the performance or safety of the gas grill. Humming regulators will not be replaced.
Burners will not cross light each other.	Plugged ports along back of burner.	Clean burner ports. See burner maintenance instructions.
"Paint" appears to be peeling inside lid or hood.	Grease build-up on inside surfaces.	This is not a defect. The finish on the lid and hood is porcelain, and will not peel. The peeling is caused by hardened grease, which dries into paint-like shards, that flake off. Regular cleaning will prevent this. See cleaning instructions.
Burner output on "high" setting is too low. (Rumbling noise and fluttering blue flame at burner surface.)	Lack of gas. Supply hose is pinched. Dirty or clogged orifice. Spider webs or other matter in venturi tube. Propane regulator in "low flow" state.	Check gas level in propane cylinder. Reposition supply hose as necessary. Clean burner orifice. Clean out venturi tube. Ensure lighting procedure is followed carefully. All gas grill valves must be in the off position when the tank valve is turned on. Turn tank on slowly to allow pressure to equalize. See lighting instructions.
Infrared burner (if equipped) flashes back (during operation the burner abruptly makes a loud "whoosh" sound, followed by a continuous blow-torch type sound and grows dim.)	Ceramic tiles overloaded with grease drippings and build-up. Ports are clogged. Burner overheated due to inadequate ventilation (too much grill surface covered by griddle or pan.) Cracked ceramic tile. Leaking gasket surrounding the ceramic tile, or a weld failure in the burner housing.	Turn burner off and allow to cool for at least two minutes. Relight burner and burn on high for at least five minutes or until the ceramic tiles are evenly glowing red. Ensure that no more than 75% of the grill surface is covered by objects or accessories. Turn burner off and allow to cool for at least two minutes, then relight. Allow burner to cool and inspect very closely for cracks. If any cracks are found, contact your authorized Napoleon dealer to order a replacement burner assembly. Contact your authorized Napoleon dealer for instructions on ordering a replacement burner assembly.
Pilot will not light. (if equipped)	Lack of gas. Obstruction in pilot orifice. Electrode wire loose or off. Dirty pilot electrode. Pilot is actually lit.	After turning pilot knob to high, wait approximately 20-30 seconds for air to purge the gas supply line while pressing igniter. Fill propane cylinder. During initial set-up or after tank has been refilled, it is best to light one of the tube burners before lighting the pilot burner. This enables the gas to reach the valves on the manifold more quickly. Clean pilot orifice. Replace lead wire. Clean pilot electrode. The pilot flame, especially on natural gas units is very difficult to see. Place your hand 1 in. (2.5 cm) above grill surface over the pilot burner to feel for heat.

KEEP YOUR RECEIPT AS PROOF OF PURCHASE TO VALIDATE YOUR WARRANTY.

Ordering Replacement Parts

Warranty Information

MODEL: _____

DATE OF PURCHASE: _____

SERIAL NUMBER: _____

(Record information here for easy reference)

Before contacting the Customer Care Department, check the NAC Website for more extensive cleaning, maintenance, troubleshooting and parts replacement instructions at www.napoleongrills.com. Contact the factory directly for replacement parts and warranty claims. Our Customer Care Department is available between 9 AM and 5 PM (Eastern Standard Time) at 1-866-820-8686 or fax at 1-705-727-4282. To process a claim, we must be provided with the following information:

1. Model and serial number of the unit.
2. Part number and description.
3. A concise description of the problem ('broken' is not sufficient).
4. Proof of purchase (photocopy of the invoice).

In some cases the Customer Care Representative could request to have the parts returned to the factory for inspection before providing replacement parts. These parts must be shipped prepaid to the attention of the Customer Care Department with the following information enclosed:

1. Model and serial number of the unit.
2. A concise description of the problem ('broken' is not sufficient).
3. Proof of purchase (photocopy of the invoice).
4. Return Authorization Number - provided by the Customer Care Representative.

Before contacting customer care, please note that the following items are not covered by the warranty:

Costs for transportation, brokerage or export duties.

Labor costs for removal and reinstallation.

Costs for service calls to diagnose problems.

Discoloration of stainless steel parts.

Part failure due to lack of cleaning and maintenance, or use of improper cleaners (oven cleaner).



CAUTION! During unpacking and assembly we recommended you wear work gloves and safety glasses for your protection. Although we make every effort to make the assembly process as problem free and safe as possible, it is characteristic of fabricated steel parts that the edges and corners might be sharp and could cause cuts if handled incorrectly.



ATTENTION! Lors du déballage et de l'assemblage, nous vous conseillons de porter des gants de travail et des lunettes de sécurité pour votre protection. Malgré tous nos efforts pour assurer que l'assemblage soit aussi sécuritaire et sans problème que possible, il se peut que les bords et les coins des pièces usinées en acier soient coupants et qu'ils causent des coupures si les pièces ne sont pas manipulées correctement.

Getting Started

1. Remove all cart panels, hardware, and grill head from carton. Raise lid and remove any components packed inside. Use the parts list to ensure all necessary parts are included.
2. Do not destroy packaging until the grill has been fully assembled and operates to your satisfaction.
3. Assemble the grill where it is to be used, lay down cardboard or a towel to protect parts from being lost or damaged while assembling.
4. Most stainless steel parts are supplied with a protective plastic coating that must be removed prior to using grill.
5. Follow all instructions in the order that they are laid out in this manual.
6. Two people are required to lift the grill head onto the assembled cart.

If you have any questions about assembly or grill operation, or if there are damaged or missing parts please call our Customer Care Department at 1-866-820-8686 between 9 AM and 5 PM (Eastern Standard Time).

Pour Commencer

1. Retirez tous les panneaux, le matériel et le gril du carton d'emballage. Soulevez le couvercle et enlevez les composants qui se trouvent à l'intérieur. Servez-vous de la liste de pièces pour vous assurer que toutes les pièces nécessaires sont incluses.
2. Ne détruisez pas l'emballage jusqu'à ce que le gril ait été complètement assemblé et qu'il fonctionne à votre satisfaction.
3. Assemblez le gril là où il sera utilisé et posez un carton ou une serviette afin d'éviter de perdre ou d'endommager les pièces lors de l'assemblage.
4. La plupart des pièces en acier inoxydable possèdent un revêtement de plastique protecteur qui doit être enlevé avant d'utiliser le gril.
5. Suivez toutes les instructions dans l'ordre donné dans ce manuel.
6. Deux personnes sont requises pour soulever la cuve de gril et la placer sur le chariot assemblé.

Si vous avez des questions à propos de l'assemblage ou du fonctionnement du gril, ou si des pièces sont manquantes ou endommagées, veuillez appeler notre département du Service aux Consommateurs au 1-866-820-8686 entre 9 h et 17 h (heure normale de l'Est).

TOOLS REQUIRED FOR ASSEMBLY (tools not included)

OUTILS REQUIS POUR L'ASSEMBLAGE (outils non inclus)

3/8 (10mm)

Wrench,
ratchet or driver
Tournevis ou clé,
cliquet de 3/8
(10mm)



Flat and Philips
screwdrivers
Tournevis plat et
phillips



Pliers
Pinces



Hammer
Marteau



1.



2 X N570-0026 (#14 x 1/2")



3/8"(10mm)

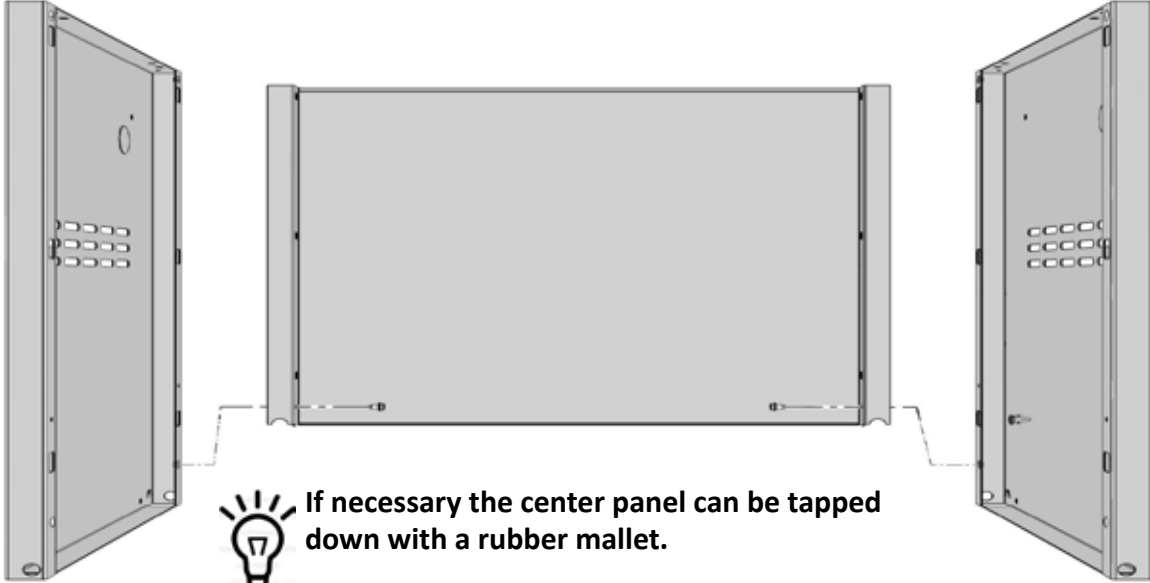

If necessary the center panel can be tapped down with a rubber mallet.

Si nécessaire, le panneau central peut être enfoncé avec un maillet en caoutchouc.

2.

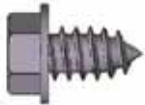

4 X N570-0026 (#14 X1/2")



3/8"(10mm)

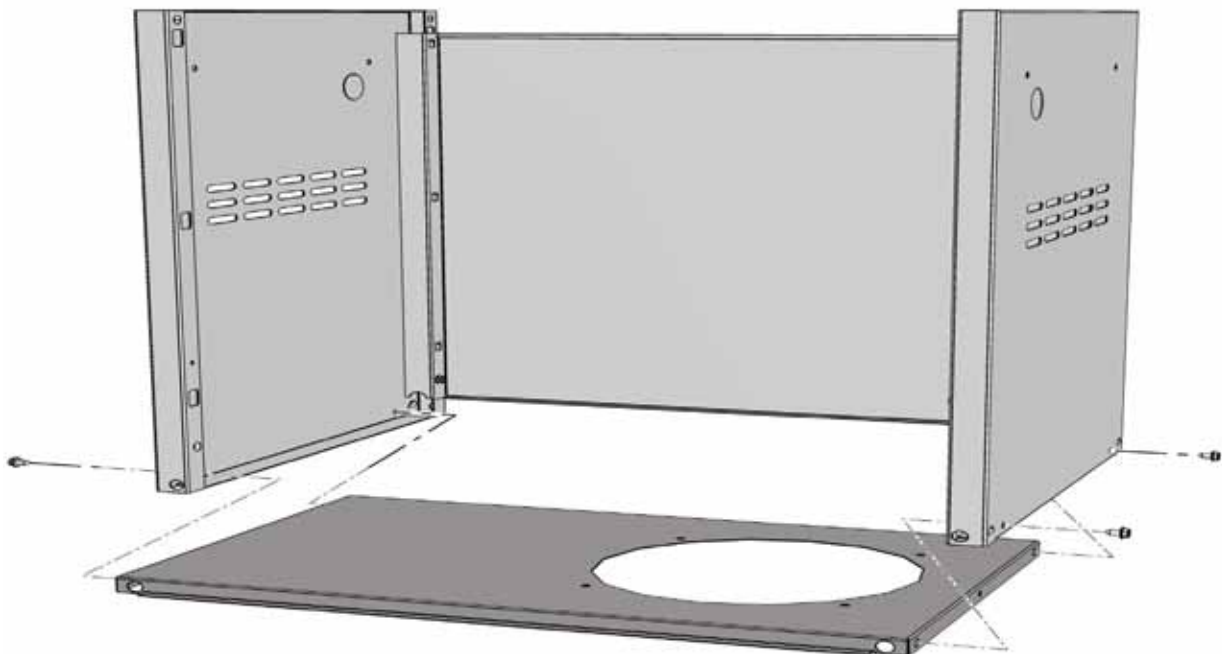

3.



4 x N570-0026 (#14 x 1/2")



3/8"(10mm)



If necessary the cross beam can be tapped down with a rubber mallet.

Si nécessaire, le barre de traverse peut être enfoncé avec un maillet en caoutchouc.

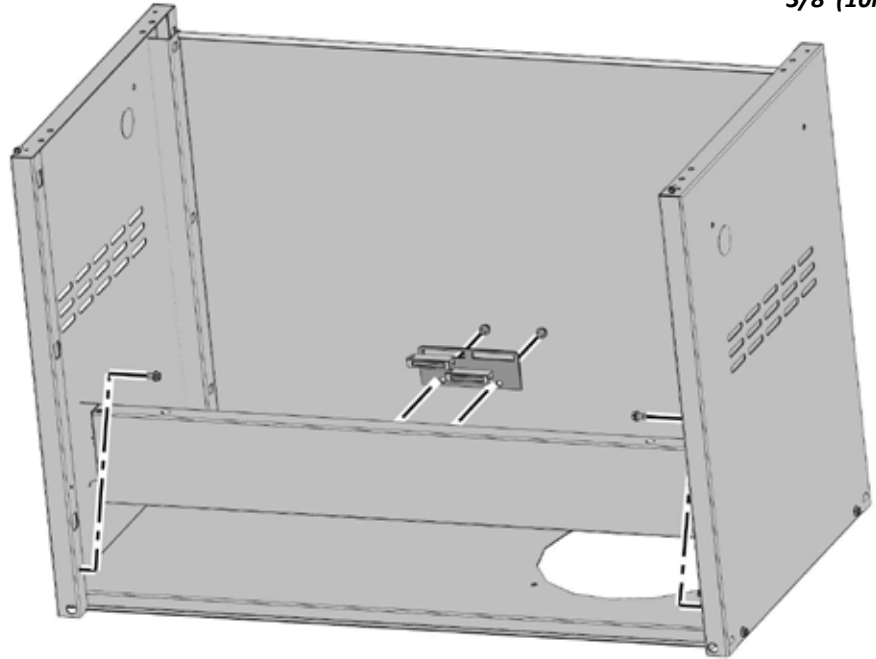

4.



4 x N570-0026 (#14 x 1/2")



3/8"(10mm)

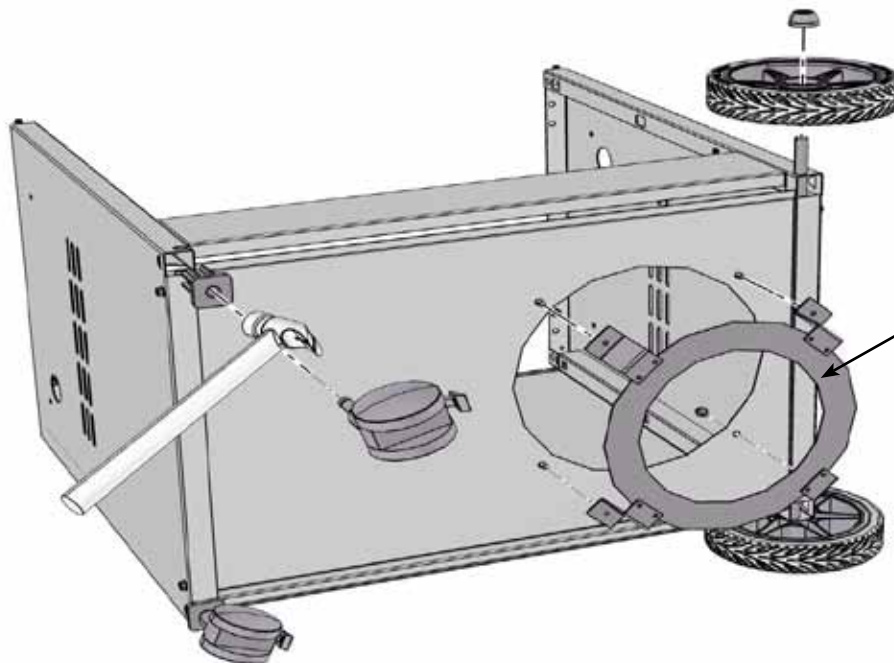

Propane Only
Propane Seulement

5.



4 x N570-0026 (#14 x 1/2")

Two people are required for this step.

Deux personnes sont nécessaires pour cette étape.

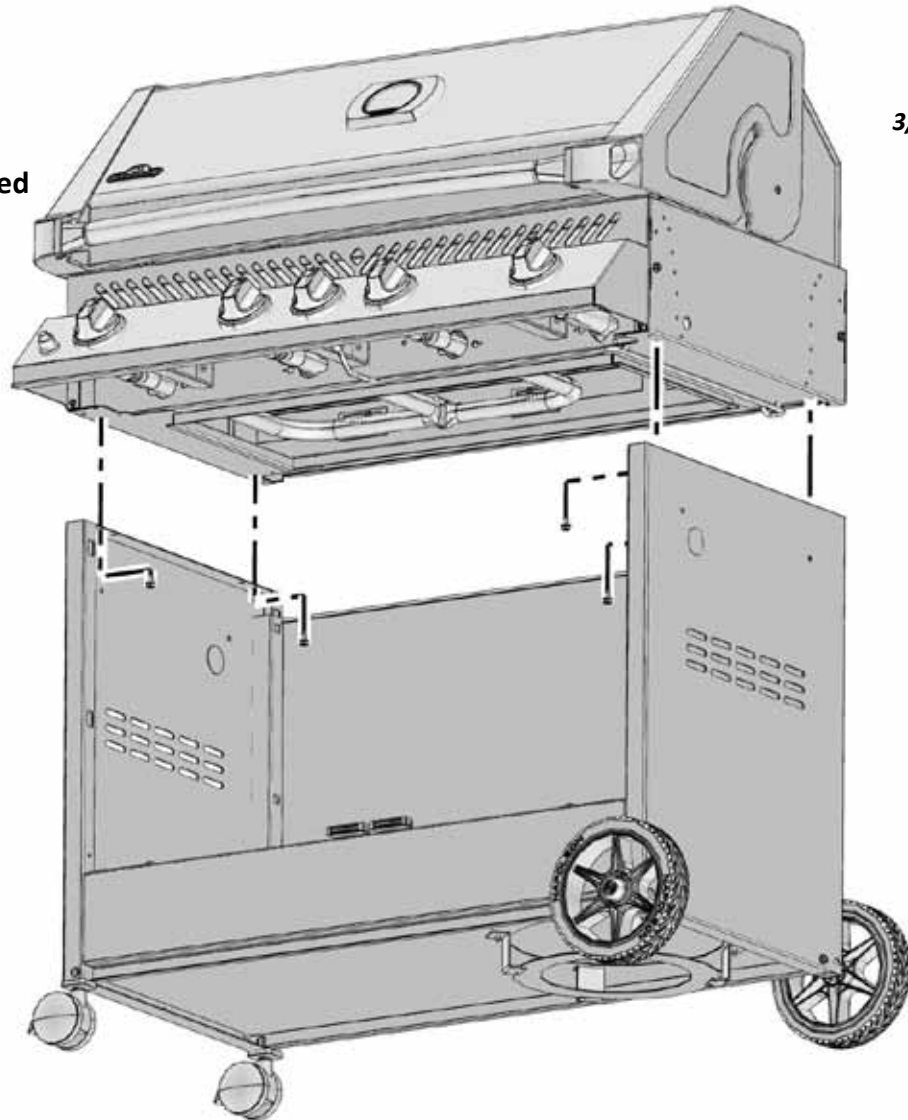

3/8" (10mm)

6.

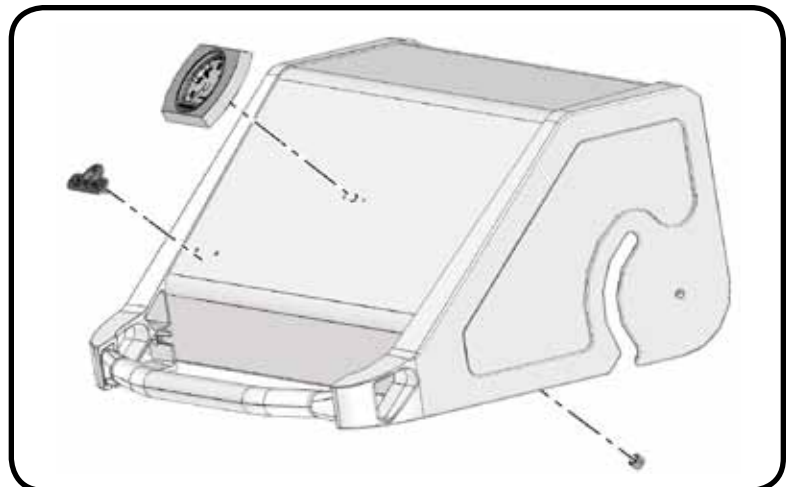
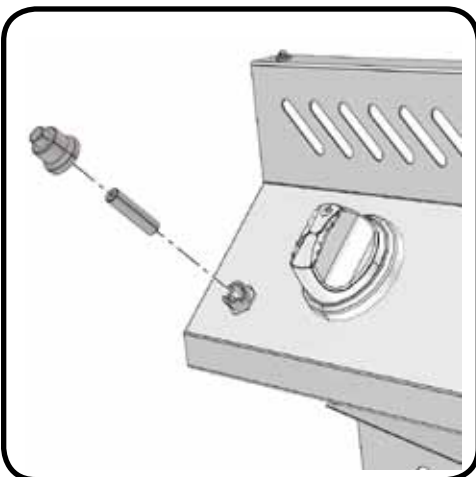

7.



2 x N570-0026 (#14 x 1/2")



3/8"(10mm)

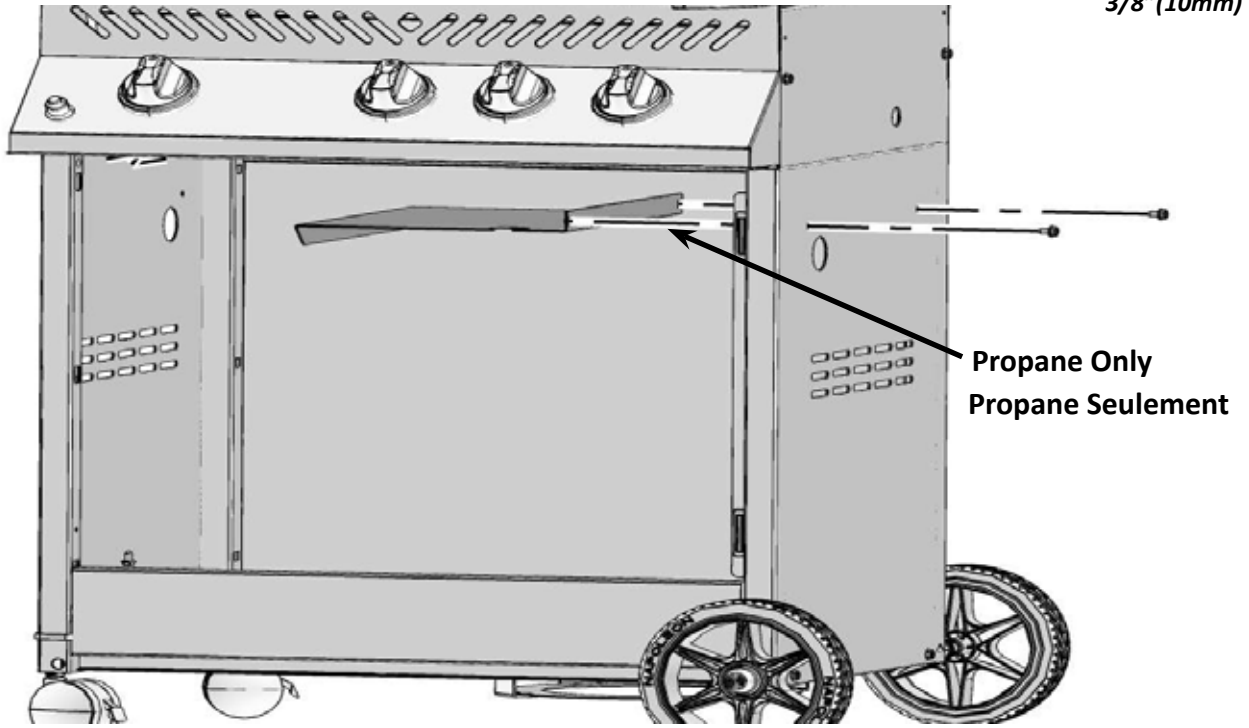

8.

disposable grease tray
jetable du récipient à graisse

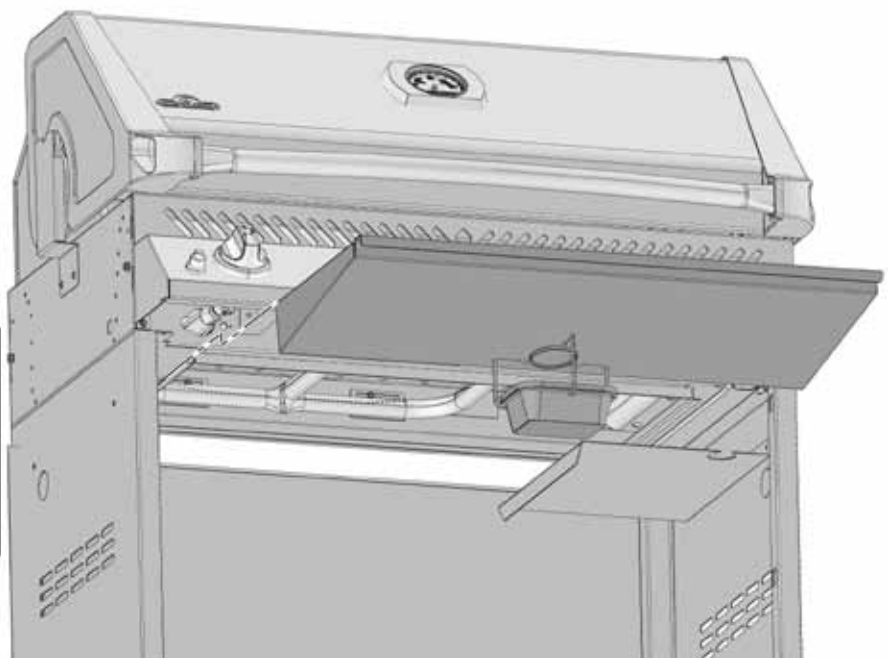
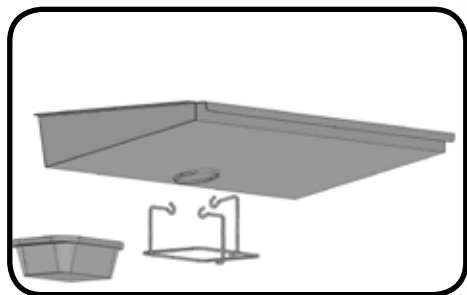

9.



2 x N570-0026 (#14 x 1/2")

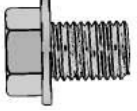

4 x N570-0029 (1/4-20 X 3/8")



4 x N735-0002 (1/4")



3/8"(10mm)

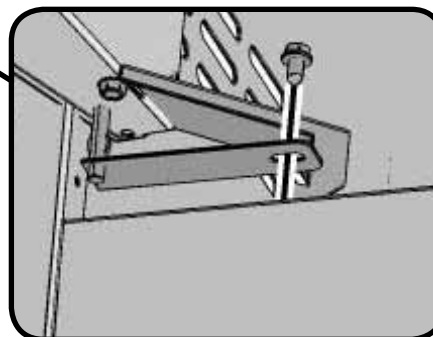
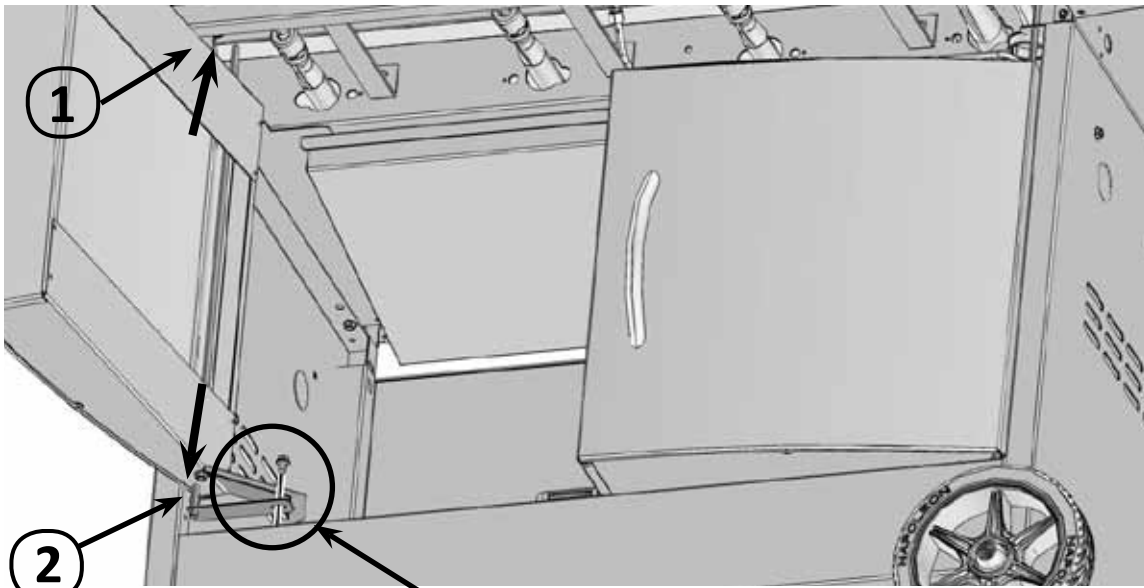
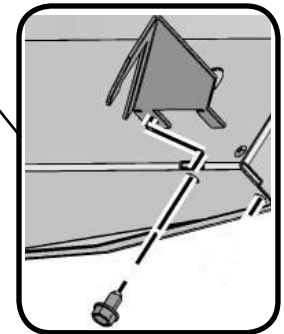
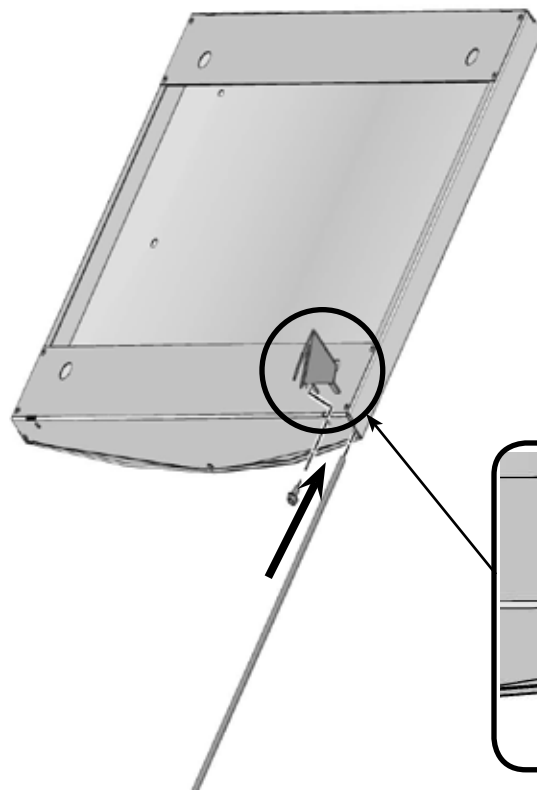
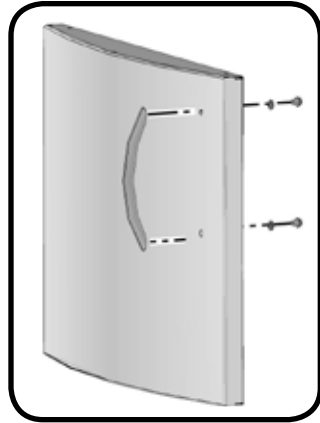

10.



10 x N570-0076 (#8 X1/2")



4 x N570-0026 (#14 X1/2")



3/8"(10mm)

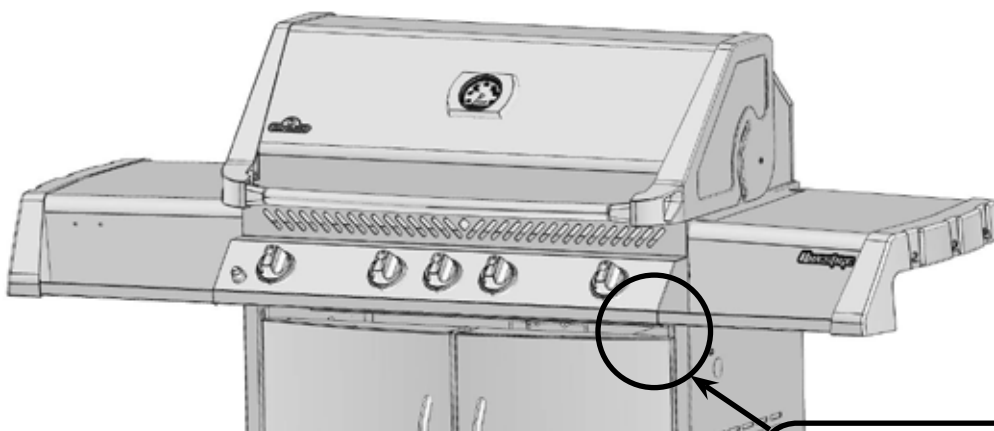
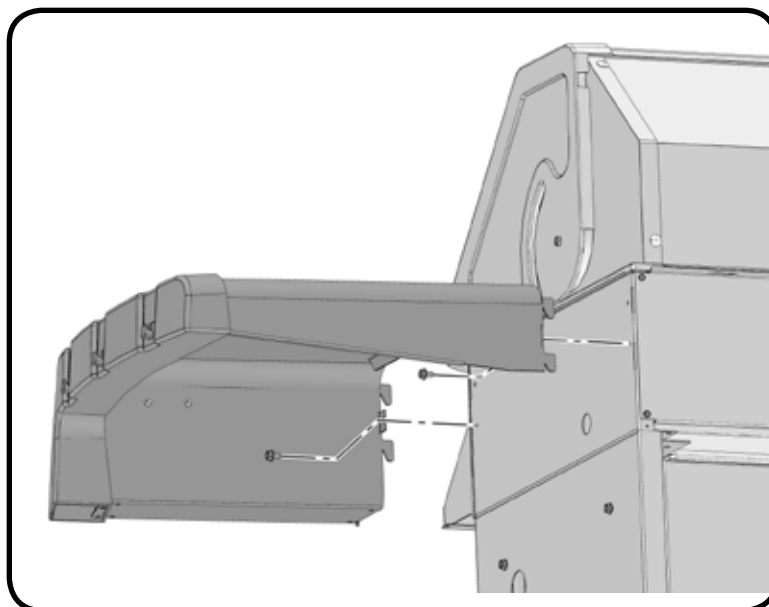
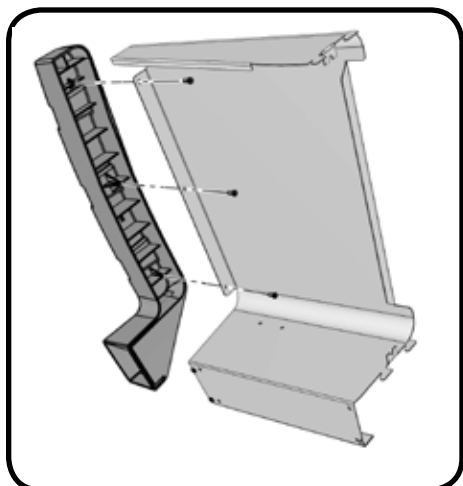

Twist tab to lock
in place.

Tournez la patte
pour verrouiller.

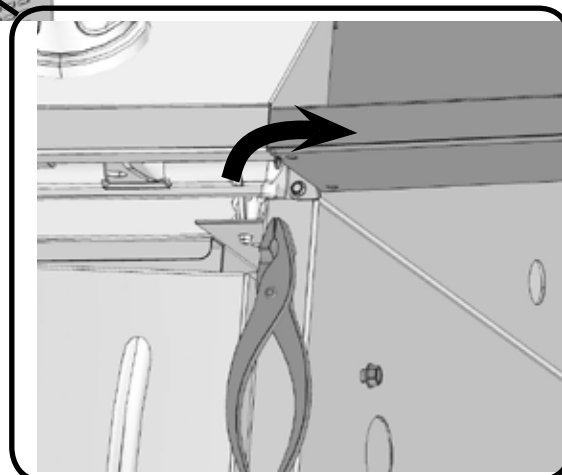

11.

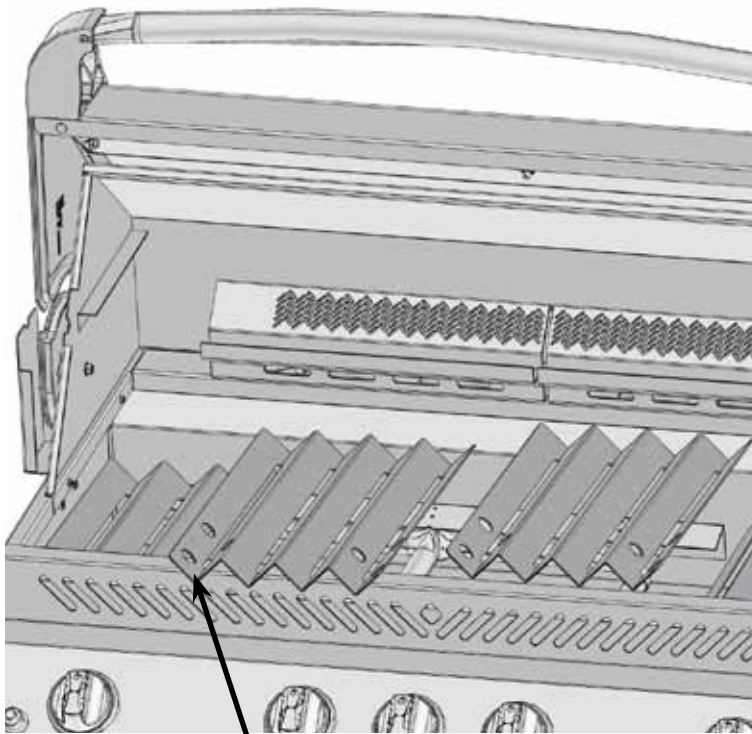

Ensure holes in sear plates are positioned to the front of the grill.

Assurez-vous que les trous dans les plaques de brûleur soient placés à l'avant du gril.

N305-0027



N520-0019



N305-0026

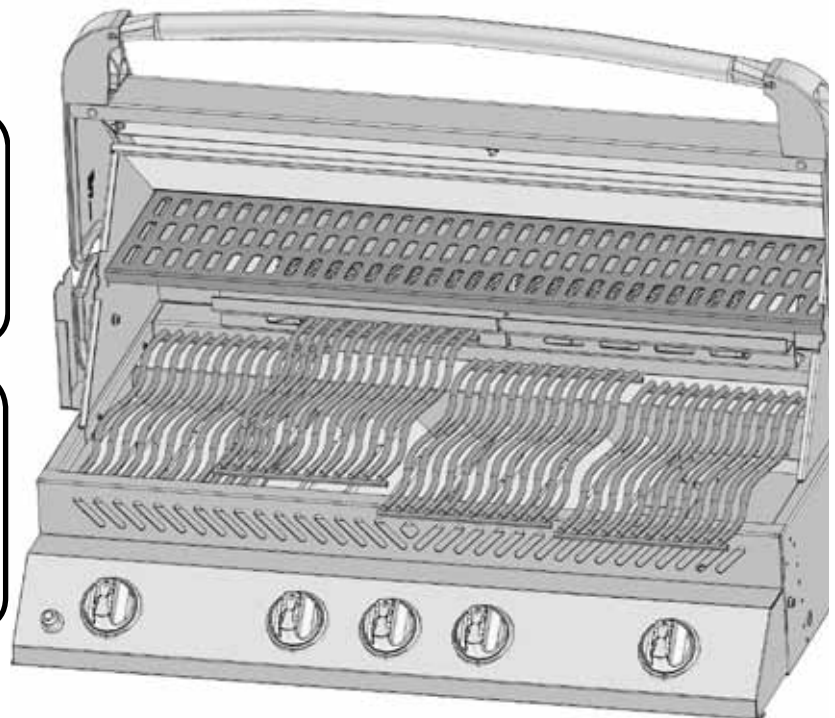
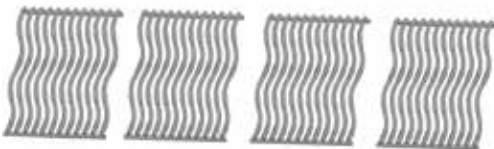

Rotisserie Kit Assembly Instruction

(included with most rear burner units)

Assemble rotisserie kit components as shown.

Instructions D'assemblage De L'ensemble De Rôtissoire

(inclus avec la plupart des appareils avec brûleur arrière)

Assemblez les composantes de la rôtissoire tel qu'illustré.

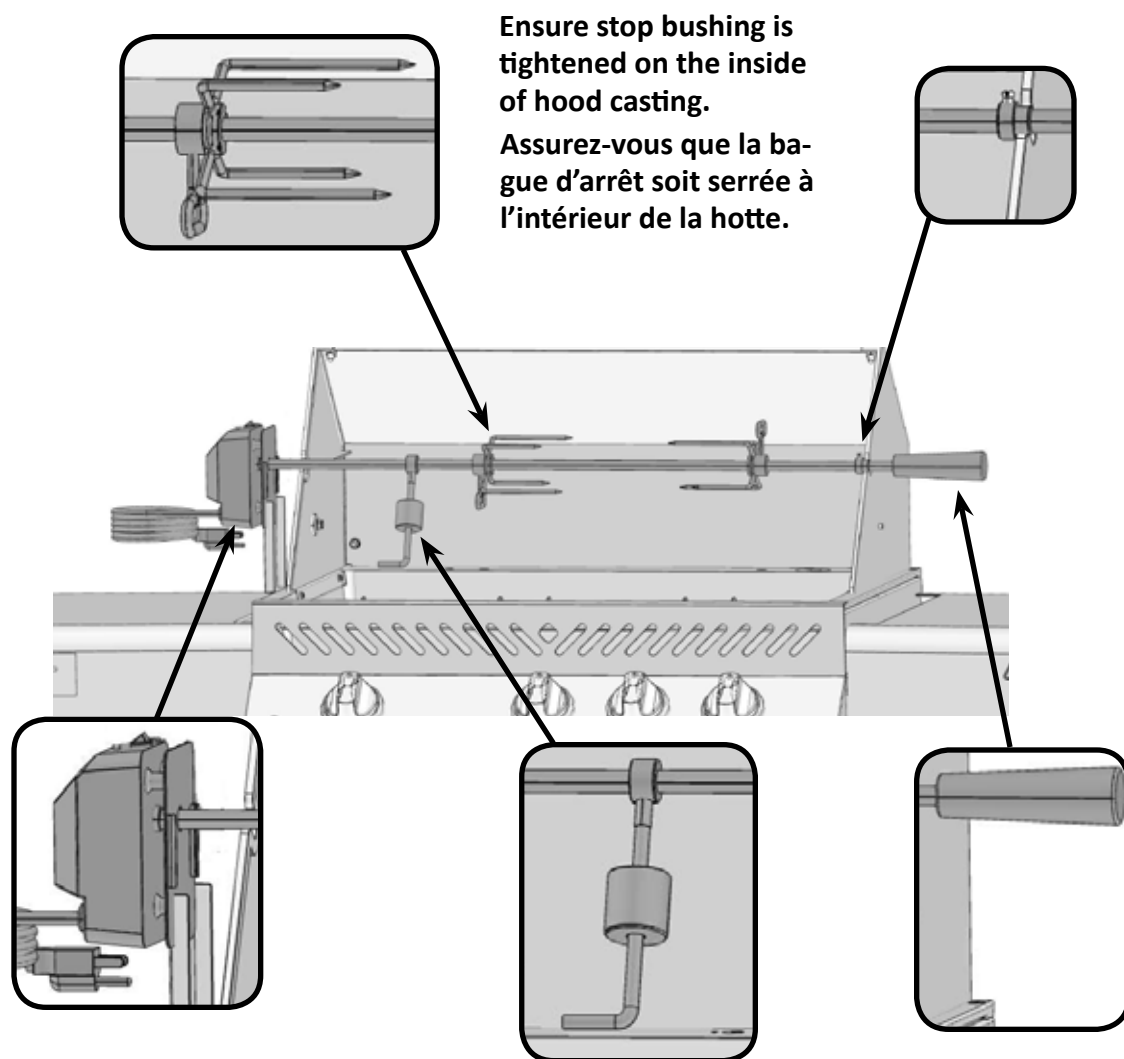

Propane Only – Proper Hose Connection
Propane Seulement - Branchement Adéquat Du Boyau

WARNING! Ensure the hose does not contact any high temperature surfaces, or it may melt and leak causing a fire.



AVERTISSEMENT! Assurez-vous que le boyau ne touche à aucune surface à haute température sinon il risque de fondre, de provoquer une fuite et causer un feu.

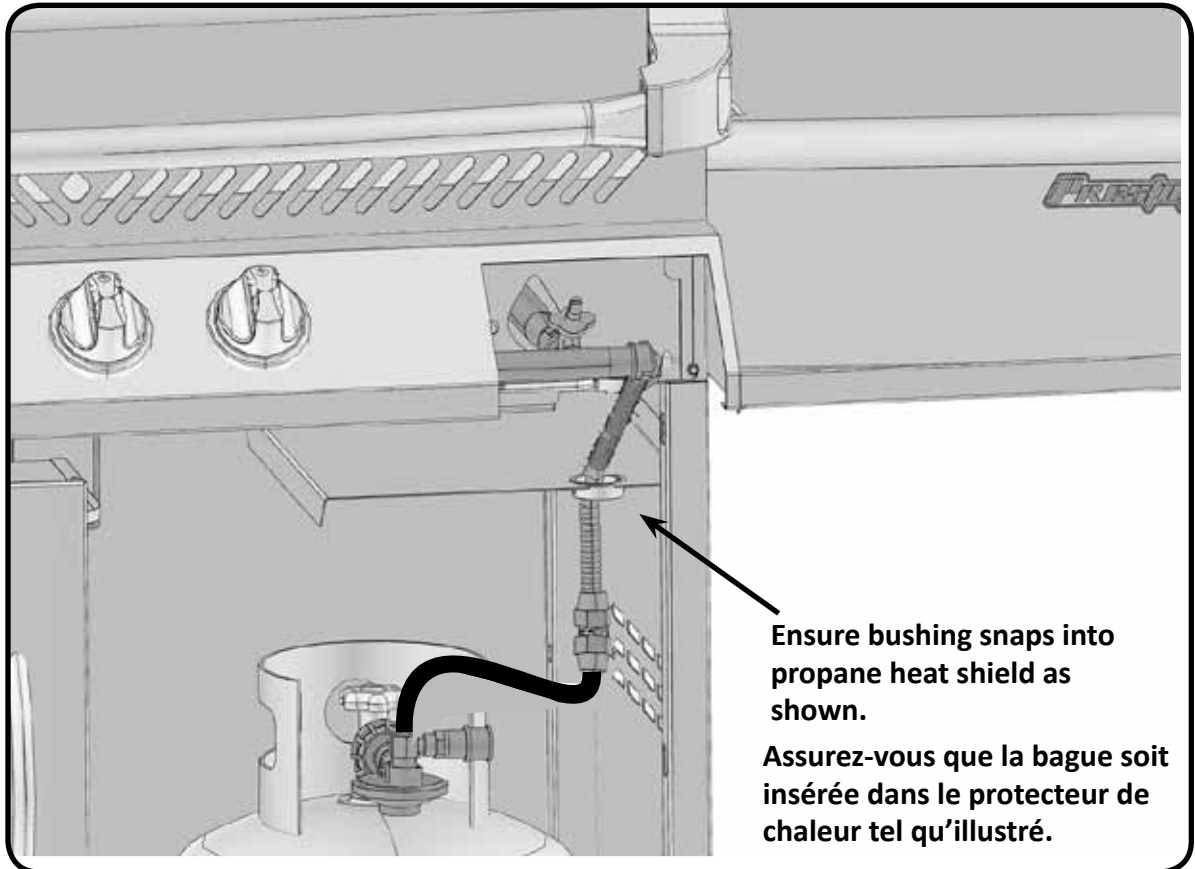

Natural Gas Only – Proper Hose Connection

Gaz Naturel Seulement - Branchement Adéquat Du Boyau



WARNING! The installation must be performed by a licensed gas fitter, and all connections must be leak tested before operating the grill.

AVERTISSEMENT! L'installation doit être effectuée par un installateur certifié pour le gaz et tous les raccords doivent être testés pour des fuites avant de faire fonctionner le grill.

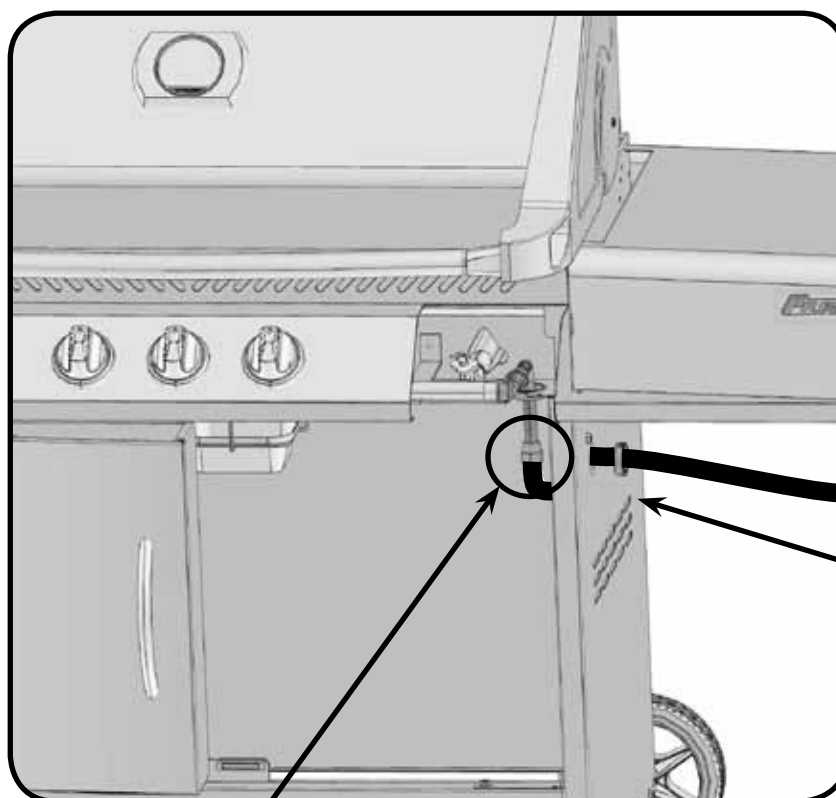

Ensure bushing snaps into side panel as shown.
Assurez-vous que la bague soit insérée dans le panneau latéral tel qu'illustré.

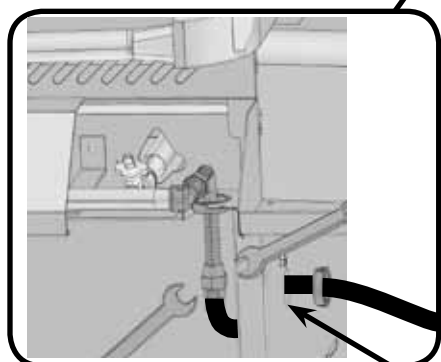

Knockout
Disque Poinçonné



WARNING – FIRE HAZARD
ATTENTION - RISQUE D'INCENDIE



WARNING! Do not route hose underneath drip pan.
AVERTISSEMENT! Ne pas passer le tuyau d'alimentation sous le tiroir d'égouttement afin de garder.

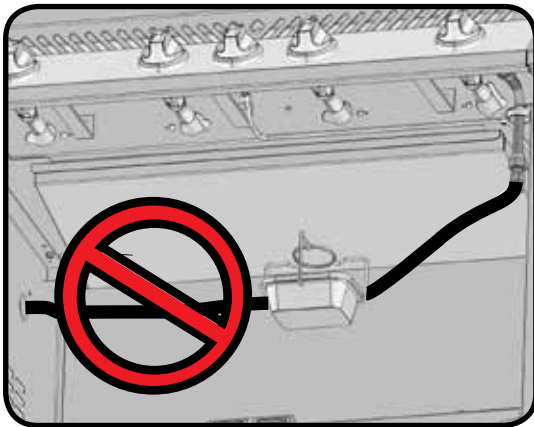
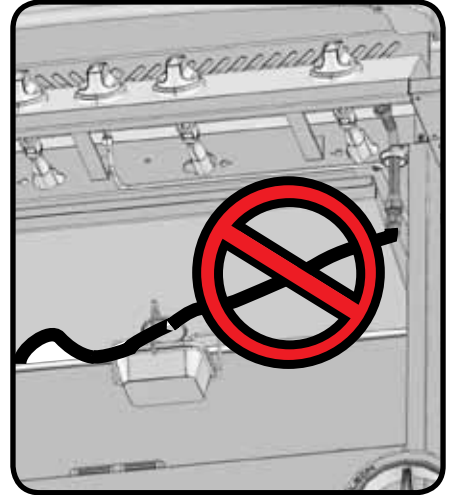

WARNING! Hose must be routed through right side panel only. Do not route hose through left side panel and underneath drip pan.

AVERTISSEMENT! Le boyau doit être acheminé à travers le panneau droit seulement. N'acheminez pas le boyau à travers le panneau gauche et en dessous du tiroir d'égouttement.



WARNING! Do not route hose over top of rear panel.
AVERTISSEMENT! N'acheminez pas le boyau par-dessus le panneau arrière.

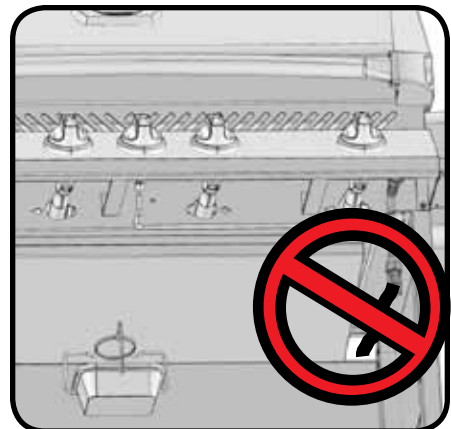

WARNING! Ensure the hose does not contact any high temperature surfaces, or it may melt and leak causing a fire.
AVERTISSEMENT! Assurez-vous que le boyau ne touche à aucune surface à haute température sinon il risque de fondre, de provoquer une fuite et causer un feu.

Leak Testing Instructions



WARNING! A leak test must be performed annually and each time a cylinder is hooked up or if a part of the gas system is replaced.



WARNING! Never use an open flame to check for gas leaks. Be certain no sparks or open flames are in the area while you check for leaks. Sparks or open flames will result in a fire or explosion, damage to property, serious bodily injury, or death.



Leak testing: This must be done before initial use, annually, and whenever any gas components are replaced or serviced. Do not smoke while performing this test, and remove all sources of ignition. See Leak Testing Diagram for areas to check. Turn all burner controls to the off position. Turn gas supply valve on.



Brush a half-and-half solution of liquid soap and water onto all joints and connections of the regulator, hose, manifolds and valves.



Bubbles will indicate a gas leak. Either tighten the loose joint or have the part replaced with one recommended by the Napoleon Customer Care department and have the grill inspected by a certified gas installer.

If the leak cannot be stopped, immediately shut off the gas supply, disconnect it, and have the grill inspected by a certified gas installer or dealer. Do not use the grill until the leak has been corrected.

Test De Détection De Fuites



AVERTISSEMENT! Il doit être fait avant la première utilisation, annuellement et à chaque fois qu'une pièce du système de gaz est remplacée ou réparée



AVERTISSEMENT! N'utilisez pas une flamme nue pour vérifier pour des fuites de gaz. Assurez-vous qu'il n'y ait aucune étincelle ni flamme nue à proximité de l'endroit à vérifier. Les étincelles ou les flammes nues provoqueront un feu ou une explosion, causant des dommages matériels, des blessures graves ou des pertes de vie.



Test De Fuites: Il doit être fait avant la première utilisation, annuellement et à chaque fois qu'une pièce du système de gaz est remplacée ou réparée. Ne fumez pas et enlevez toutes sources d'allumage lorsque vous faites ce test. Consultez le schéma de test de fuites pour voir les endroits à tester.

1 - Fermez tous les boutons des brûleurs. Ouvrez la soupape de la bonbonne.

2 - Appliquez une solution de deux parts égales de savon liquide et d'eau sur tous les joints du régulateur, le tuyau et ses raccords.

3 - Des bulles indiqueront une fuite de gaz. Resserrez le joint ou remplacez la pièce avec une autre recommandée par le détaillant.

4 - Si la fuite ne peut être réparée, fermez l'alimentation de gaz à la bonbonne, enlevez-la et faites inspecter votre gril par votre fournisseur de gaz ou détaillant. N'utilisez pas l'appareil jusqu'à ce que la fuite soit réparée.

5 - Fermez la soupape de la bonbonne.

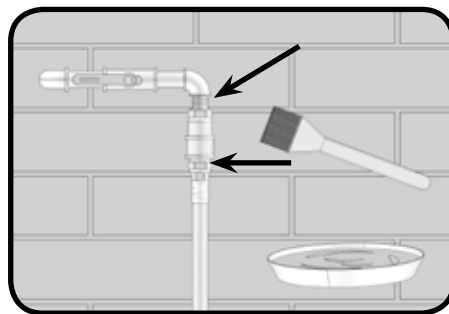
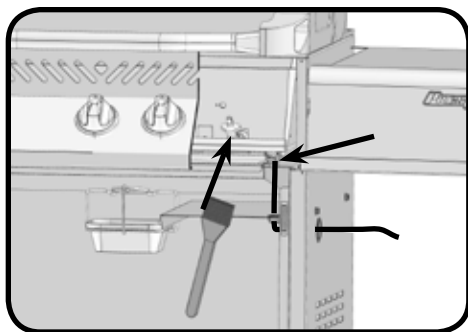
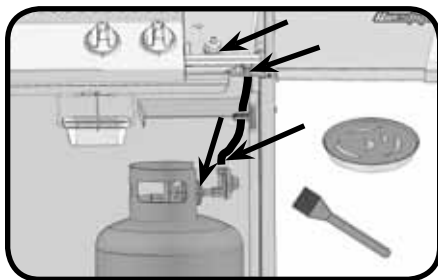

Parts List / Liste Des Pièces

Item	Part #	Description	PT600
1	n135-0020g	left side lid casting / moulage gauche du couvercle	x
2	w385-0045	NAPOLEON logo / logo NAPOLEON	x
	w450-0005	logo spring clips / écrous à ressort pour logo	x
	n510-0002	black silicone lid bumper / pare-chocs du couvercle (silicone noir)	x
3	n685-0004	temperature gauge / jauge de température	x
4	n010-0477	stainless steel lid insert / couvercle en acier inoxydable	x
	N335-0016Z	bronze lid insert / couvercle en bronze	x
5	n325-0055	lid handle / poignée du couvercle	x
6	n135-0021g	right side lid casting / moulage droite du couvercle	x
7	n570-0015	lid pivot screw / écrous du pivot	x
8	n010-0178k	hood assembly / ensemble du couvercle	x
9	n570-0008	#8 x 1/2" screw / vis #8 x 1/2"	x
10	n570-0024	1/4-20 x 1/2" screw / vis 1/4-20 x 1/2"	x
11	n735-0002	1/4" lockwasher / rondelle à ressort 1/4"	x
12	n520-0019	stainless steel warming rack / grille rechaud en acier inoxydable	x
13	n305-0026	cooking grids - stainless rod / grille de cuisson - en acier inoxydable	x
14	n305-0027	sear plate / plaque de brûleur	x
15	n590-0141	stainless steel side shelf - right / tablette latérale en acier inoxydable droite	x
16	n120-0007g	LUXIDIO side shelf end cap, right / embout en LUXIDIO de le tablette latérale droite	x
17	n570-0076	#8 x 1/2" screw / vis #8 x 1/2"	x
18	n590-0140	stainless steel side shelf - left / tablette latérale en acier inoxydable gauche	x
19	n120-0006g	LUXIDIO side shelf end cap, left / embout en LUXIDIO de le tablette latérale gauche	x
21	n010-0184	back burner housing - left (infra-red) / boîtier du brûleur arrière - gauche (infra-rouge)	x
22	n010-0185	back burner housing - right (infra-red) / boîtier du brûleur arrière - droite (infra-rouge)	x
23	n100-0015	back burner / brûleur arrière	x
24	n200-0019	burner grease shield / plaque de brûleur	x
25	n100-0014	main burner / brûleur principal	x
26	n570-0021	#8 x 1" screw / vis #8 x 1"	x
27	n475-0016	rotisserie mount / support de la rôtissoire	x
28	n570-0019	10-24 x 1/4" screw / vis 10-24 x 1/4"	x
29	n450-0009	10-24 nut / écrou 10-24	x
30	n010-0423	base / cuve	x
31	n710-0046	drippan / tiroir d'égouttement	x
32	n160-0006	grease tray holder / support du récipient à graisse	x
33	n710-0062	replacement grease tray / ensemble de récipients à graisse	x
34	n200-0018g	back cover / couvercle arrière	x
35	n475-0142	control panel / panneau de contrôle	x
36	n380-0015	control knob, main burner / bouton de contrôle principal	x
37	n630-0003	bezel retaining spring / ressort de retenue de monture	x
38	n051-0007	control knob bezel / monture de bouton de commande	x
39	n255-0001	90 degree elbow (3/8 F to 1/2 FP) / coude degrés (3/8 F to 1/2 FP)	x
40	n530-0003	1-outlet regulator / ensemble de tuyau de régulateur à 1 sortie	p
	n345-0001	10ft n/g hose c/w quick disconnect / tuyau de 10 pieds avec débranchement rapide	n
	n345-0003	10ft n/g hose - hose only / tuyau de 10 pieds - tuyau seulement	n
42	n432-0013	manifold tube c/w brackets / tuyau collecteur avec fixations	x
43a	n725-0007	rear burner valve / soupape brûleur arrière	p
43b	n725-0008	rear burner valve / soupape brûleur arrière	n
	n720-0045	rear burner supply tube / tuyau d'alimentation brûleur arrière	x
	n010-0188	rear burner orifice assembly / ensemble des orifices brûleur arrière	p
	n010-0189	rear burner orifice assembly / ensemble des orifices brûleur arrière	n
44a	n725-0009	main burner valve / soupape brûleur principal	p
44b	n725-0010	main burner valve / soupape brûleur principal	n

Parts List / Liste Des Pièces

Item	Part #	Description	PT600
	n455-0007	#59 main burner orifice / bec d'orifice #59 brûleur principal	p
	n455-0008	#53 main burner orifice / bec d'orifice #53 brûleur principal	n
47	n475-0222g	left side cart enclosure / panneau gauche pour chariot	x
48	n357-0015	electronic ignition, 3-spark / allumeur électronique - 3 étincelles	x
	n240-0016	main burner electrode left / électrode du brûleur principal gauche	x
	n240-0021	main burner electrode right / électrode du brûleur principal droite	x
	n240-0001	rear burner electrode / électrode du brûleur arrière	x
	n350-0054	collector box - main burner / boîte du collecteur du brûleur principal	x
51	n555-0012	door pivot rod / tige-pivot de porte	x
52	n010-0559SS	cart door assembly stainless steel / ensemble de porte pour chariot acier inoxydable	x
53	n325-0049	door handle / poignée de porte	x
	n570-0029	1/4-20 x 3/8" screw / vis 1/4-20 x 3/8"	x
	n735-0002	1/4" lockwasher / rondelle à ressort 1/4"	x
55	n570-0086	#14 x 1/2" screw / vis #14 x 1/2"	x
56a	n590-0153g	bottom shelf - propane / tablettes inférieur - propane	p
56b	n590-0152g	bottom shelf - natural / tablettes inférieur - naturel	n
57	n475-0280g	rear cart panel / panneau arrière pour chariot	x
58	n080-0130p	door stop bracket - left / support d'arrêt de porte - gauche	x
59	n080-0166p	door stop bracket - right / support d'arrêt de porte - droite	x
60	n585-0025p	heat shield / pare-chaleur	x
61	n080-0193p	bracket, door adjust / support, ajustement de porte	x
62	n105-0002	snap bushing / bague à pression	x
65	n525-0008g	cross beam / barre de traverse	x
69	n010-0360p	tank ring support / support de la bouteille	p
71	n080-0165p	magnet bracket / support à aimant	x
72	n430-0002	magnetic catch / loquet magnétique	x
73	n130-0010	caster assembly - each / ensemble de roulettes (unité)	x
74	n450-0023	axle cap / enjoliveur	x
76	n745-0007	wheel - each / roue (unité)	x
77	n015-0004	axle / essieu	x
	n020-0134	main assembly baggie / principal sac d'accessories pour le montage	x
	64600	rotisserie kit / ensemble de la rôtissoire	x
	63180	vinyl cover / housse en vinyle	ac
	56018	stainless steel griddle / plaque de cuisson en acier inoxydable	ac
	67600	charcoal tray / support à charbon	ac
	62007	replacement grease trays (5 pieces) foil / ensemble de récipients à graisse (5 pieces) foil	ac

x - standard

p - propane units only

p - appareils propane seulement

x - compris

n - natural gas units only

n - appareils gaz naturel seulement

ac - accessory

ac - accessoires

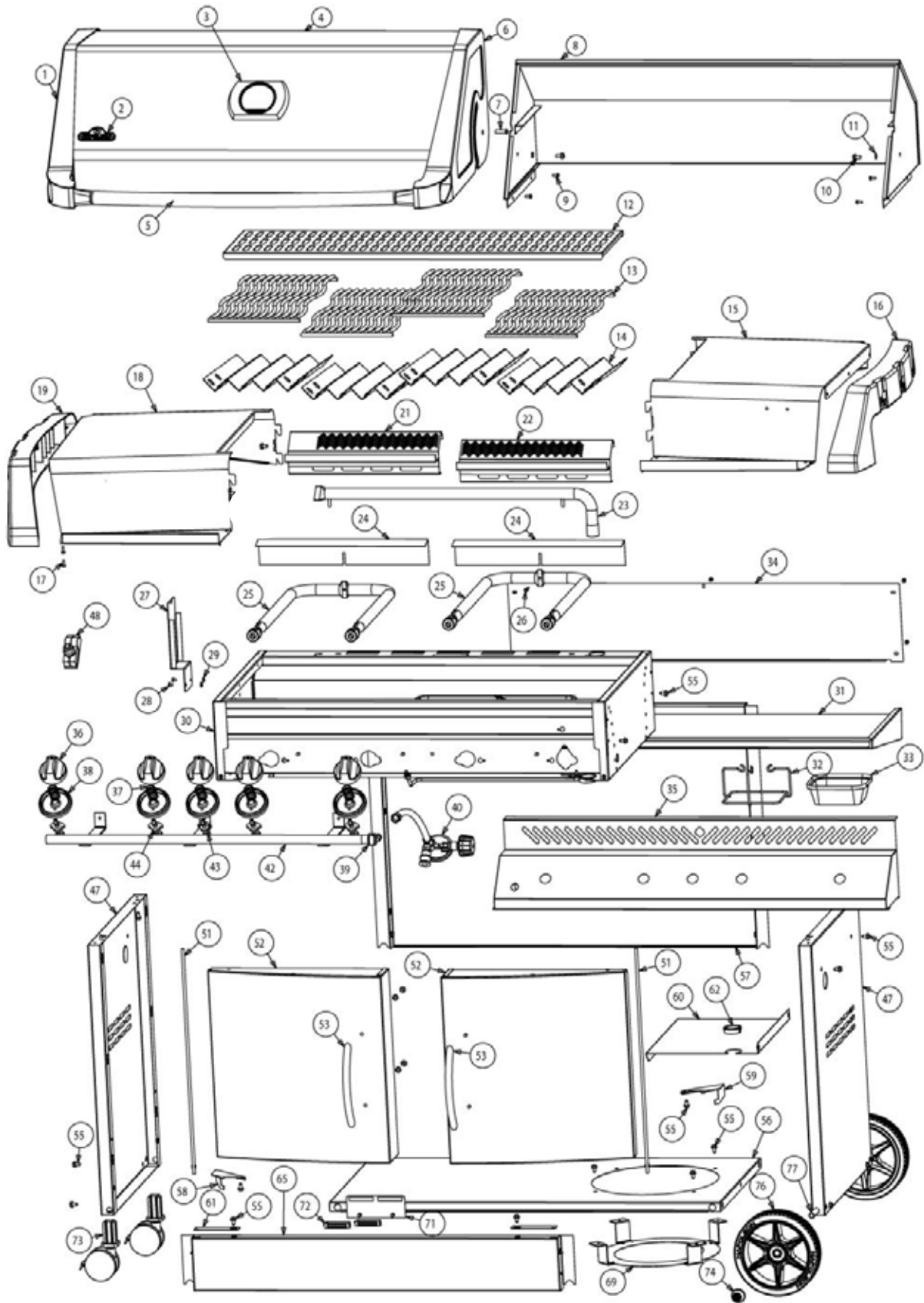



FAX TO: 705 727 4282

GOURMET GRILLS

Award Winning Products

ACCESSORIES & PARTS ORDER FORM

PLEASE PRINT CLEARLY

CONTACT NAME: _____

SHIP TO : _____

TEL : _____

FAX : _____

EMAIL: _____

VISA OR MASTERCARD # : _____ EXPIRY DATE: _____

SIGNATURE: _____

QUANTITY	PART NUMBER	DESCRIPTION

TAXES MAY APPLY
SHIPPING EXTRA

IF CONFIRMATION IS REQUIRED PLEASE INCLUDE A FAX NUMBER OR EMAIL ADDRESS



TÉLÉCOPIEZ AU: 705 727 4282

BON DE COMMANDE POUR PIÈCES/ACCESSOIRES

NOM DU CLIENT _____

ADRESSE: _____

TÉLÉPHONE : _____ FAX : _____

EMAIL: _____

VISA OU MASTERCARD : _____ DATE D'EXPIRATION : _____

SIGNATURE: _____

QUANTITÉ	NUMÉRO DE PRODUIT	DESCRIPTION

LES TAXES PEUVENT S'APPLIQUER
LES FRAIS D'EXPÉDITION SUPPLÉMENTAIRE

SI VOUS DÉSIREZ RECEVOIR UNE CONFIRMATION, VEUILLEZ INCLURE UN NUMÉRO DE
TÉLÉCOPIEUR OU UNE ADRESSE COURRIEL

